

TB 5-2520-551-24

TECHNICAL BULLETIN

INSTALLATION INSTRUCTIONS

FOR

TRUCK INSTALLATION KIT

TRQ-32(V)

Approved for public release. Distribution is unlimited.

HEADQUARTERS, DEPARTMENT OF THE ARMY

12 JANUARY 1989

TECHNICAL BULLETIN

HEADQUARTERS
DEPARTMENT OF THE ARMY
WASHINGTON, D. C., 12 January 1989

TB 5-2520-551-24

INSTALLATION INSTRUCTIONS
FOR
TRUCK INSTALLATION KIT
TRQ-32(V)

REPORTING ERRORS AND RECOMMENDING IMPROVEMENTS

You can help improve this manual. If you find any mistakes or if you know of a way to improve the procedures, please let us know. Mail your letter, DA Form 2028 (Recommended Changes to Publications and Blank Forms), or DA Form 2028-2 located in the back of this technical bulletin direct to: U.S. Army Troop Support Command, ATTN: AMSTR-MCTS, 4300 Goodfellow Boulevard, St. Louis, MO 63120-1798. A reply will be furnished directly to you.

APPROVED FOR PUBLIC RELEASE. DISTRIBUTION IS UNLIMITED.

TABLE OF CONTENTS

	Page
INTRODUCTION	1
Materials Required	1
Materials Supplied	2
Tools Required	4
INSTALLATION	6
Preliminary	6
PTO Unit	7
PTO Actuator Cable	11
Tachometer	15
Tachometer Cable Assembly	16
Tachometer Magnetic Pickup and RPM Sensor	18
Remote Radio Control Unit Mounting Bracket	19
Remote Radio Control	22
W-33 Vehicle Cable Assembly	23
Heat Sensor Switch	28
W-65 Speed Control Cable Assembly	29
Speed Control Group	36
Speed Control Magnetic Sensor	42
Tandem Hydraulic Pump	43
Hydraulic Reservoir Assembly	47
Hydraulic Lines	50
Skid Plate	54

TABLE OF CONTENTS - (Cont)

	Page
TEST AND ADJUSTMENT	56
Speed Control RPM Adjustment	56
WI R I N G D I A G R A M S	
W-67 Cable Assembly	FP-1
W-33 Cable Assembly	FP-3
W-65 Cable Assembly	FP-5
I N S T A L L A T I O N D R A W I N G S	
Truckbed Modification Drawing (2 sheets)	FP-7
Hydraulic Line Layout	FP-11

INSTALLATION INSTRUCTIONS
FOR
TRUCK INSTALLATION KIT
TRQ-32(V)

INTRODUCTION

The purpose of this Technical Bulletin is to provide procedures for modifying the M1028A vehicle and installing a TRQ-32(V) Installation Kit. These instructions may also be used to retain the Installation Kit if a vehicle change-over is required.

When installed, the Installation Kit provides vehicle engine speed control, a hydraulic pump to drive the TRQ-32(V) system power generator and air conditioner, and a remote radio control unit.

PURPOSE

This document contains the information required to modify the M-1028A1 truck for use with the AN/TRQ-32(V) system.

PERSONNEL REQUIRED: 2

MATERIALS REQUIRED (Parts and Components required in addition to the Installation Kit)

<u>QTY</u>	<u>P/N</u>	<u>NSN</u>	<u>DESCRIPTION</u>
1	M-1028A1	2320-01-158-0820	TRUCK
1	C5118904-1	5895-01-171-3476	SPEED CONTROL GROUP
1	C5118905-1	5895-01-171-4049	POWER TAKE-OFF
1	C5122481-1	5895-01-171-3475	RESERVOIR ASSEMBLY
1	C5122498-1	5895-01-171-3477	PUMP ASSEMBLY
1	C-2298/VRC	5830-00-892-3338	INTERCOM, REMOTE ELEMENT
1	H250/U	5965-00-043-3463	HANDSET
AR	M17111	9150-00-261-8317	FLUID, POWER TRANSMISSION
AR	825504-4	9150-00-261-8317	HYDRAULIC FLUID
1	C5118949-1		PALLET, SHELTER ALIGNMENT
AR		8030-00-182-2508	LOCKTIGHT
AR		8305-00-267-3015	CLOTH
AR	MIL-A-46106 (TYPE 1)		RTV
2	C5122508-1		HOSE ASSEMBLY
2	C5122509-1		HOSE ASSEMBLY
1	C5122510-1		HOSE ASSEMBLY
2	C5122511-1		HOSE ASSEMBLY
1	C5122512-1		HOSE ASSEMBLY
2	C5122512-2		HOSE ASSEMBLY
1	C5131409-1		QUICK DISCONNECT, HYDRAULIC
1	C5131409-2		QUICK DISCONNECT, HYDRAULIC
1	C5131409-3		QUICK DISCONNECT, HYDRAULIC
1	C5131409-4		QUICK DISCONNECT, HYDRAULIC
1	C5131409-5		QUICK DISCONNECT, HYDRAULIC
1	C5111008-1		TUBE ASSEMBLY
1	C5111009-1		TUBE ASSEMBLY
1	C5111010-1		TUBE ASSEMBLY
1	C5111011-1		TUBE ASSEMBLY
1	C5111012-1		TUBE ASSEMBLY
1	C5111013-1		TUBE ASSEMBLY
2	AN737TW46		CLAMP, HOSE

<u>QTY</u>	<u>P/N</u>	<u>NSN</u>	<u>DESCRIPTION</u>
3	AN815-12D		UNI ON
2	AN815-4D		UNI ON
2	AN815-8D		UNI ON
1	M6000H00304		HOSE, RUBBER
1	M6000D00307		HOSE, RUBBER

MATERIALS SUPPLIED (Parts and components included in the Installation Kit)

<u>ITEM NO.</u>	<u>QTY</u>	<u>P/N</u>	<u>NSN</u>	<u>DESCRIPTION</u>
1	1	C5110943-1		BRACKET, MOUNTING
2	1	C5110944-1		BRACKET, MOUNTING
3	1	C5118946-1		SKI D PLATE
4	1	C5118947-1		BRACKET, SKI D PLATE
5	1	C5118948-1		BRACKET, SKI D PLATE
6	1	C5110651-1		BRACKET, CHANNEL
7	1	C5110649-1		BRACKET, CHANNEL
8	1	C5110649-2		BRACKET, CHANNEL
9	1	C5110650-1		BRACKET, CLAMP
10	1	C5110650-2		BRACKET, CLAMP
11	1	C5110650-3		BRACKET, CLAMP
12	1	C5110650-4		BRACKET, CLAMP
13	1	C5122612-1		PLATE, CLEARANCE, HOLE
14	1	C5122613-1		PLATE, RETAINER HOSE
15	1	C5131109-1		CLAMP
16	1	C5131109-2		CLAMP
17	2	C5131109-3		CLAMP
18	1	C5131109-4		CLAMP
19	1	C5131109-5		CLAMP
20	1	C5110654-1		PLATE, COVER
21	2	C5110654-2		PLATE, COVER
22	3	C5110654-3		PLATE, COVER
23	1	C5110654-4		PLATE, COVER
24	1	C5110529-1		BRACKET, MOUNTING
25	1	C5110530-1		BRACKET, MOUNTING
26	1	C5110559-1		BRACKET, SPEED CONTROL
27	1	C5110652-1		BRACKET, MOUNTING
28	1	C5110698-1		GAUGE PANEL
29	1	C5110787-1		CABLE ASSEMBLY (W33)
30	1	C5118950-1		TRANSFER CASE LOCKOUT ASSEMBLY
31	1	C5118955-1		CABLE ASSEMBLY (W65)
32	1	C5122557-1		RPM REGULATOR ASSEMBLY
33	1	C5122564-1		CABLE ASSEMBLY (W67)
34	1	C5122610-1		BRACKET, HEAT SENSOR
35	1	C5122611-1		COVER, HEAT SENSOR
36	8	MS90725-6	5305-00-068-0502	SCREW, CAP, HEXAGON
37	16	MS90725-8	5305-00-225-3839	SCREW, CAP, HEXAGON
38	9	MS90725-62	5305-00-269-3213	SCREW, CAP, HEXAGON
39	2	MS90725-111	5305-00-782-9495	SCREW, CAP, HEXAGON
40	10	MS90726-13	5305-00-071-2510	SCREW, CAP, HEXAGON

MATERIALS SUPPLIED (cont.)

<u>ITEM</u>				
<u>NO.</u>	<u>QTY</u>	<u>P/N</u>	<u>NSN</u>	<u>DESCRIPTION</u>
41	2	MS90726-14	5305-00-071-2237	SCREW, CAP, HEXAGON
42	2	MS90726-17	5305-00-071-2234	SCREW, CAP, HEXAGON
43	9	MS51971-1	5310-00-903-5966	NUT, PLAIN
44	6	MS51971-3	5310-00-913-8881	NUT, PLAIN
45	24	AN960C416	5310-00-531-9515	WASHER, FLAT
46	9	AN960C616	5310-00-167-0804	WASHER, FLAT
47	28	NAS1640-416	5310-00-933-8121	WASHER, LOCK
48	11	NAS1640-616	5310-00-984-6042	WASHER, LOCK
49	2	MS35338-143	5310-00-933-8778	WASHER, LOCK
50	2	MS51959-70B	5305-00-733-3041	SCREW, MACHINE
51	2	C5131383-1		NUT, U
52	4	C5131353-1		NUT, CLIP
53	1	C5131037-1		FILTER ASSY
54	AR	C5131118-1		SLEEVE, PROTECTIVE
55	AR	C5131118-2		SLEEVE, PROTECTIVE
56	AR	C5131118-3		SLEEVE, PROTECTIVE
57	45	MS3367-3-0	5975-00-074-2072	STRAP, TIEDOWN
58	2	AN737TW22	4730-00-278-9200	CLAMP, HOSE
59	8	AN737TW30	4730-00-720-0167	CLAMP, HOSE
60	4	AN737TW58	4730-00-278-0424	CLAMP, HOSE
61	1	C5110708-1		TACHOMETER
62	2	MS35307-333	5306-00-817-4989	SCREW, CAP
63	4	NAS1640-516		WASHER, LOCK
64	4	MS51971-2	5310-00-767-0445	NUT, PLAIN
65	4	MS51957-29	5305-00-054-6653	SCREW, MACHINE
66	2	MS24693C3	5305-00-957-2383	SCREW, MACHINE
67	2	NAS1640-4		WASHER, LOCK
68	2	NAS671C4	5310-00-208-3786	NUT, PLAIN HEXAGON
69	1	C5131106-1		NUT, LOCK
70	1	MS35498-4	5325-00-174-5317	GROMMET, RUBBER
71	1	MS25036-148	5940-00-813-0698	TERMINAL, LUG
72	AR	M16878/4BGB9	6145-01-203-4055	WIRE, ELECTRICAL
73	45	MS3367-2-0	5975-00-899-4606	STRAP, TIEDOWN
74	2	MS35307-312	5305-00-207-2297	SCREW, CAP
75	2	MS35307-309	5305-00-579-5283	SCREW, CAP
76	1	MS51958-62	5305-00-059-3658	SCREW, MACHINE
77	4	NAS1640-10	5310-00-442-6911	WASHER, LOCK
78	1	MS24693C272	5305-00-957-7811	SCREW, MACHINE
79	2	MS51958-64	5305-00-059-3660	SCREW, MACHINE
80	2	NAS671C10	5310-00-812-4292	NUT, PLAIN HEXAGON
81	1	C5110621-1		COVER, FLYWHEEL
82	1	MS20913-1S	4730-00-221-2136	PLUG, PIPE
83	1	MS35489-18	5325-00-276-6090	GROMMET, RUBBER
84	AR	C5131401-1		THREAD LUBRICANT
85	1	MS35309-310	5305-00-550-3935	SCREW, CAP
86	AR	C5131400-1		THERMAL JOINT COMPOUND
87	2	AN960C6	5310-00-531-9514	WASHER, FLAT
88	6	M7928/5-3	5940-01-079-1647	TERMINAL, LUG & SPLICES
89	8	M7928/5-4	5940-01-079-1375	TERMINAL, LUG & SPLICES
90	1	M7928/5-5	5940-01-079-1936	TERMINAL, LUG & SPLICES
91	1	MS35333-110	5310-00-022-8847	WASHER, LOCK

MATERIALS SUPPLIED (cont.)

<u>ITEM NO.</u>	<u>QTY</u>	<u>P/N</u>	<u>NSN</u>	<u>DESCRIPTION</u>
92	AR	M23053/5-108-0		INSULATION SLEEVING, ELECTRICAL
93	1	C5132683-1		SPACER, SKID PLATE
94	12	MS27130S31	5310-01-015-1021	NUT, PLAIN

TOOLS REQUIRED (All necessary tools required to install the kit)

<u>QTY</u>	<u>SIZE/TYPE</u>	<u>NSN</u>	<u>DESCRIPTION</u>
2	12"	5120-00-264-3796	ADJUSTABLE WRENCH
1	15"	5120-00-423-6728	ADJUSTABLE WRENCH
1		5120-00-293-3509	CENTER PUNCH
1	3/16"	5120-00-132-0496	COMBINATION WRENCH
1	1/4"	5120-00-288-9997	COMBINATION WRENCH
1	5/16"	5120-00-228-9503	COMBINATION WRENCH
1	3/8"	5120-00-228-9504	COMBINATION WRENCH
1	7/16"	5120-00-228-9505	COMBINATION WRENCH
2	1/2"	5120-00-228-9506	COMBINATION WRENCH
1	9/16"	5120-00-228-9507	COMBINATION WRENCH
1	11/16"	5120-00-228-9509	COMBINATION WRENCH
2	3/4"	5120-00-228-9510	COMBINATION WRENCH
1	7/8"	5120-00-228-9512	COMBINATION WRENCH
1	1"	5120-00-228-9514	COMBINATION WRENCH
1	1-1/4"		COMBINATION WRENCH
1	10 mm		COMBINATION WRENCH
1	15 mm		COMBINATION WRENCH
1		5120-00-132-6913	CRIMPING TOOL
1	4"	5110-00-239-8253	DIAGONAL CUTTING PLIERS
1	.201		DRILL BIT
1	.332		DRILL BIT
1	.375		DRILL BIT
1	.406		DRILL BIT
1	.500		DRILL BIT
1	3/8"	5120-00-240-5396	DRIVE RATCHET HANDLE
1	3/8"	5120-00-240-5364	DRIVE SWIVEL
1	3"		EXTENSION
2	6"		EXTENSION
1	16 OZ.	5120-00-061-8543	HAMMER
1	1/8"	5120-00-240-5292	HEX KEY WRENCH
1	5/32"	5120-00-198-5392	HEX KEY WRENCH

TOOLS REQUIRED (cont.)

<u>QTY</u>	<u>SIZE/TYPE</u>	<u>NSN</u>	<u>DESCRIPTION</u>
1	1-1/2"		HOLE SAW
1	9/32"		NUT DRIVER
1	3/8"		PORTABLE ELECTRIC DRILL
1	1/2"		PORTABLE ELECTRIC DRILL
1		5120-00-294-8913	PUTTY KNIFE
1			RIVET NUT INSTALLATION TOOL
1		5110-00-234-6551	ROUND FILE
1			SABER SAW
1	NO. 1	5120-00-240-8716	SCREW DRIVER CROSS TIP
1	NO. 2	5120-00-240-8713	SCREW DRIVER CROSS TIP
1	1/4"	5120-00-596-8502	SCREW DRIVER FLAT TIP (1-1/2" SHAFT)
1	1/8"	5120-00-236-2140	SCREW DRIVER FLAT TIP
1	3/16"	5120-00-278-1270	SCREW DRIVER FLAT TIP
1	1/4"	5120-00-222-8852	SCREW DRIVER FLAT TIP
1	NO. 1		SCREW DRIVER FLAT TIP
1	NO. 2		SCREW DRIVER FLAT TIP
1	3/16"		SCREW DRIVE OFFSET FLAT TIP
1		5120-00-223-7397	SLIP JOINT PLIERS
1	7/16"	5120-00-227-6703	SOCKET
1	1/2"	5120-00-237-0977	SOCKET
1	9/16"	5120-00-227-6704	SOCKET
1	5/8"	5120-00-237-4973	SOCKET
1	10 mm		SOCKET
1	15 mm		SOCKET
1	17 mm		SOCKET
1	ROLL	3493-00-185-4708	SOLDER
1	60 WATT	3493-00-134-9202	SOLDERING IRON
1	.250-20UNC-2B		TAP
1		5120-01-020-7755	TIEDOWN TOOL
1	20-30 AWG	5110-00-364-2854	WI RE STRIPPER

INSTALLING THE KIT

PRELIMINARY

WARNING

Disconnect batteries before performing following steps.

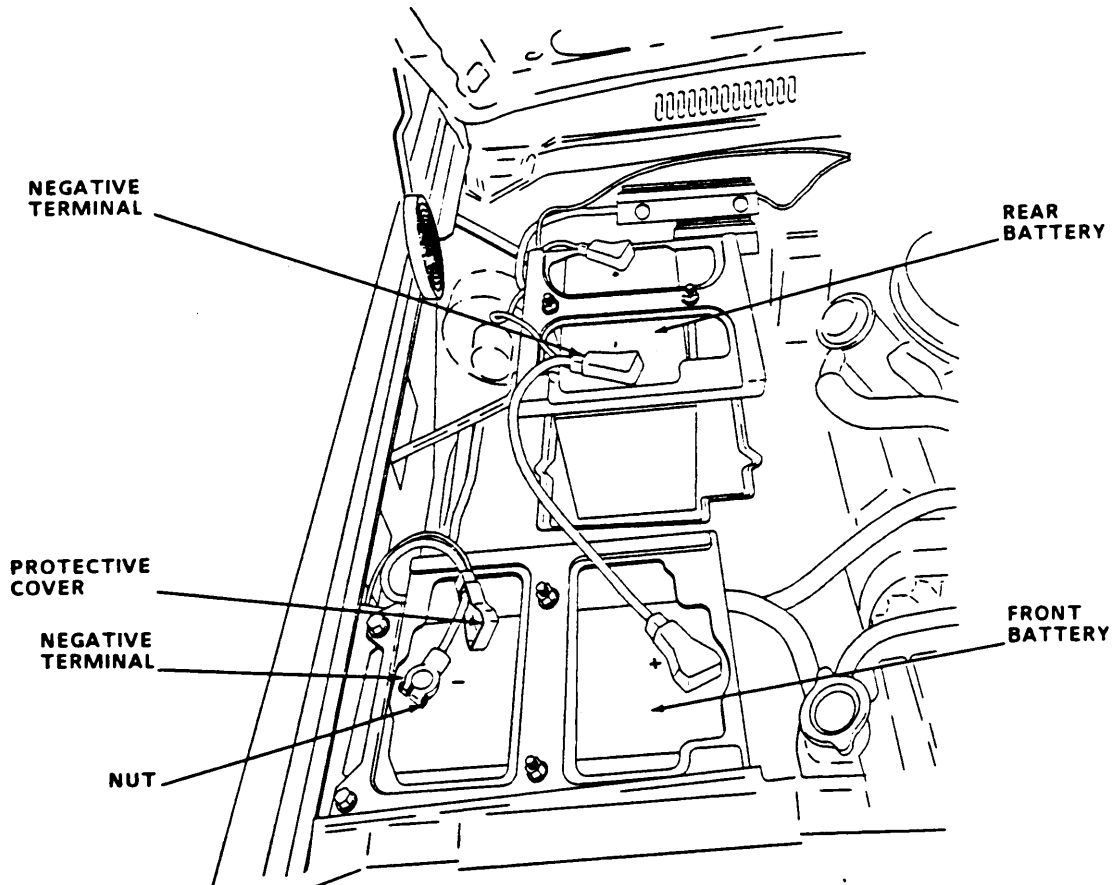

CAUTION

Prevent damage to engine electronic components. Disconnect batteries in following order: First, disconnect negative (-) terminal from rear battery. Second, disconnect negative (-) terminal from front battery.

1. Remove tailgate from truck, if necessary.
2. Lift protective cover on negative (-) terminal of rear battery. Using 9/16" combination wrench, loosen nut and disconnect cable from battery terminal.
3. Lift protective cover on negative (-) terminal of front battery. Using 9/16" combination wrench, loosen nut and disconnect cable from battery terminal.

PTO UNIT

4. Using a 9/16" combination wrench, remove and discard PTO cover plate and mounting hardware from transfer case.
5. Remove and discard old cover plate gasket from the transfer case and clean surface.
6. Install two 9/16" nuts onto PTO mounting stud to be installed. Using two 9/16" combination wrenches, tighten nuts against each other. Install PTO mounting stud into transfer case. Using a 9/16" combination wrench, tighten stud.
7. Using a 9/16" combination wrench, remove two nuts from PTO mounting stud. Using the same procedure, install the remaining five PTO mounting studs.
8. Apply RTV (MIL-A-46106, type 1) to both sides of new PTO gasket. Place gasket on transfer case.
9. Install PTO actuator cable bracket on PTO unit and tighten using 1/2" combination wrench.
10. Using 1/2" combination wrench, remove and retain bolt holding actuator arm. Move actuator arm from shipping position to normal operating position and reinstall bolt.

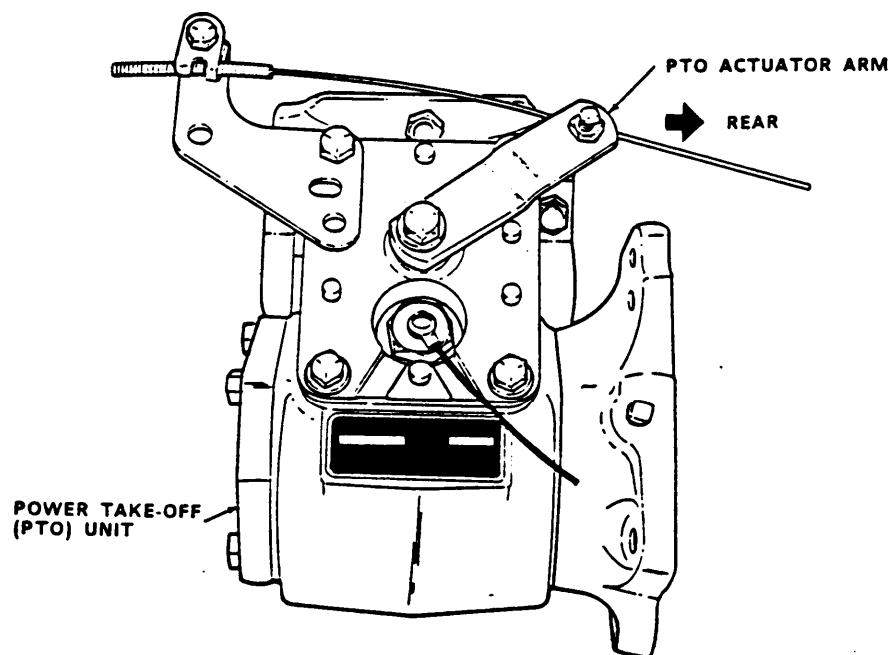

11. Using 5/16" combination wrench, install pipe plug (item 82, MS20913-1S) in PTO flange adapter.
12. Install PTO unit on transfer case. Tighten six nuts and washers securing PTO unit, using 9/16" combination wrench.
13. Using 3/4" combination wrench, remove and retain mounting nut from PTO actuator cable.

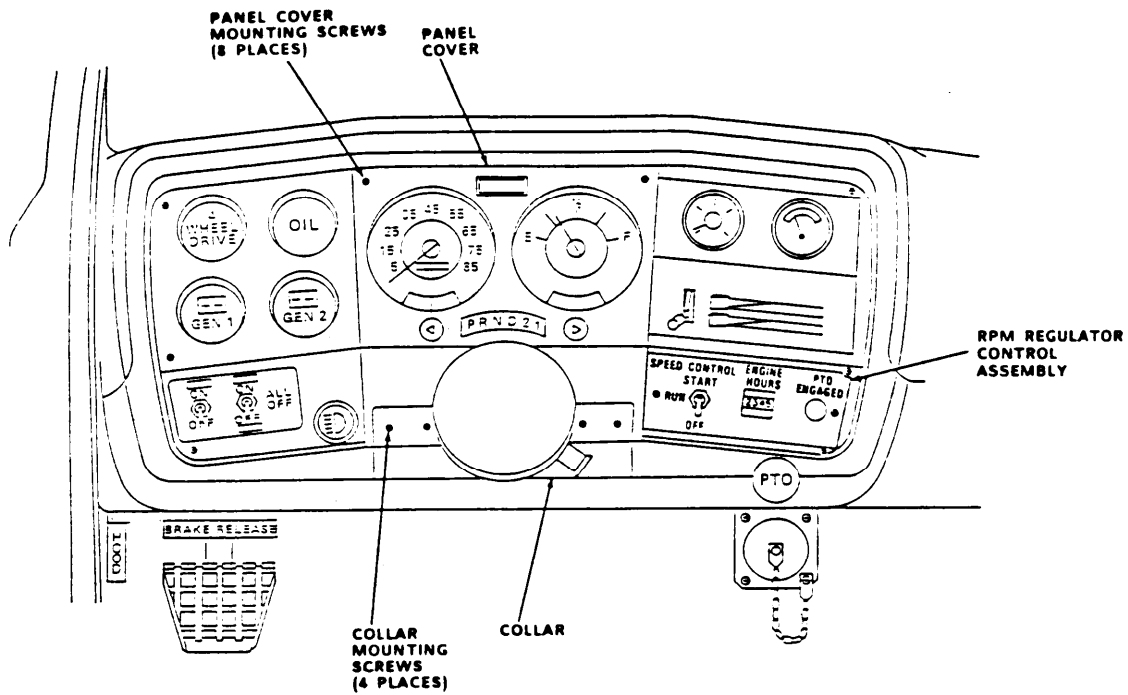

14. Below steering column, remove four screws securing plastic collar to instrument panel cover using NO.2 cross tip screwdriver. Remove and retain collar and hardware.
15. Using NO.2 cross tip screwdriver, remove eight screws securing instrument panel cover. Remove and retain hardware.
16. Pull top of instrument panel cover out about two inches and remove two warning lights by rotating 1/4 turn clockwise.

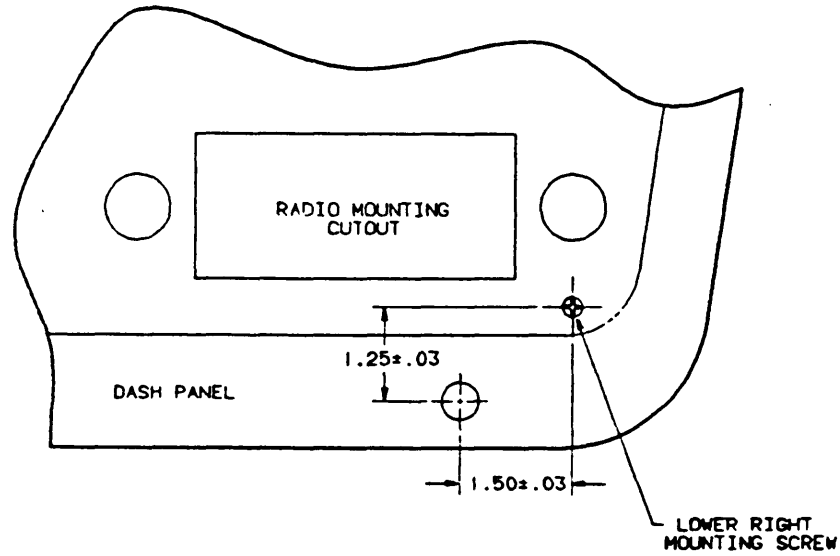

17. Measure 1.25" down and 1.5" left of lower right mounting screw on the instrument panel. Mark location with center punch. This is the center point of the hole to be drilled in the next step.
18. Using electric drill with 1/8" drill bit, drill pilot hole in dashboard.
19. Using electric drill with .500 drill bit, drill hole in dashboard. Clean burrs from hole using file.

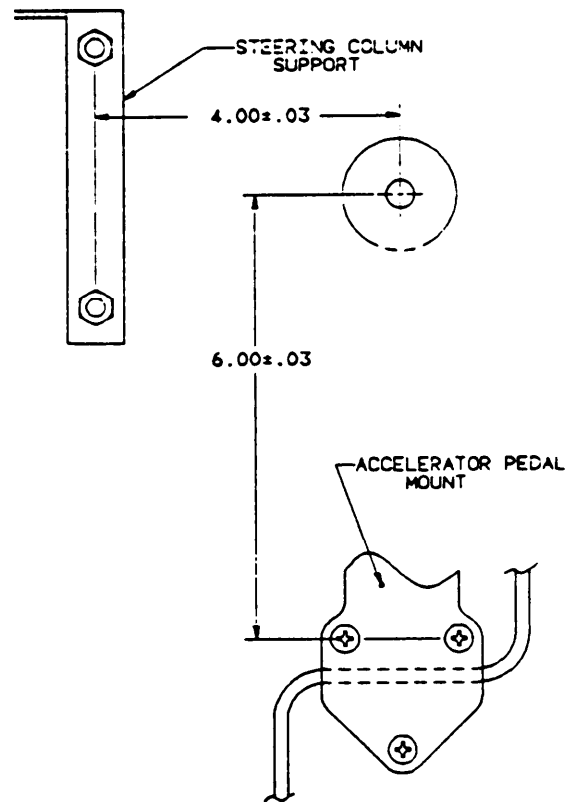

20. On firewall, locate insulation knockout 6" above upper mounting screws of accelerator pedal and 4" right of steering column support bolts. Remove and discard insulation knockout. Mark center of hole using center punch.
21. Using electric drill with 1/8" drill bit, drill pilot hole in firewall.
22. Using electric drill with .375" drill bit, drill hole in firewall.
23. On rear of instrument panel cover, using 7mm wrench, remove and discard bolt and bracket securing radio block-off cover.

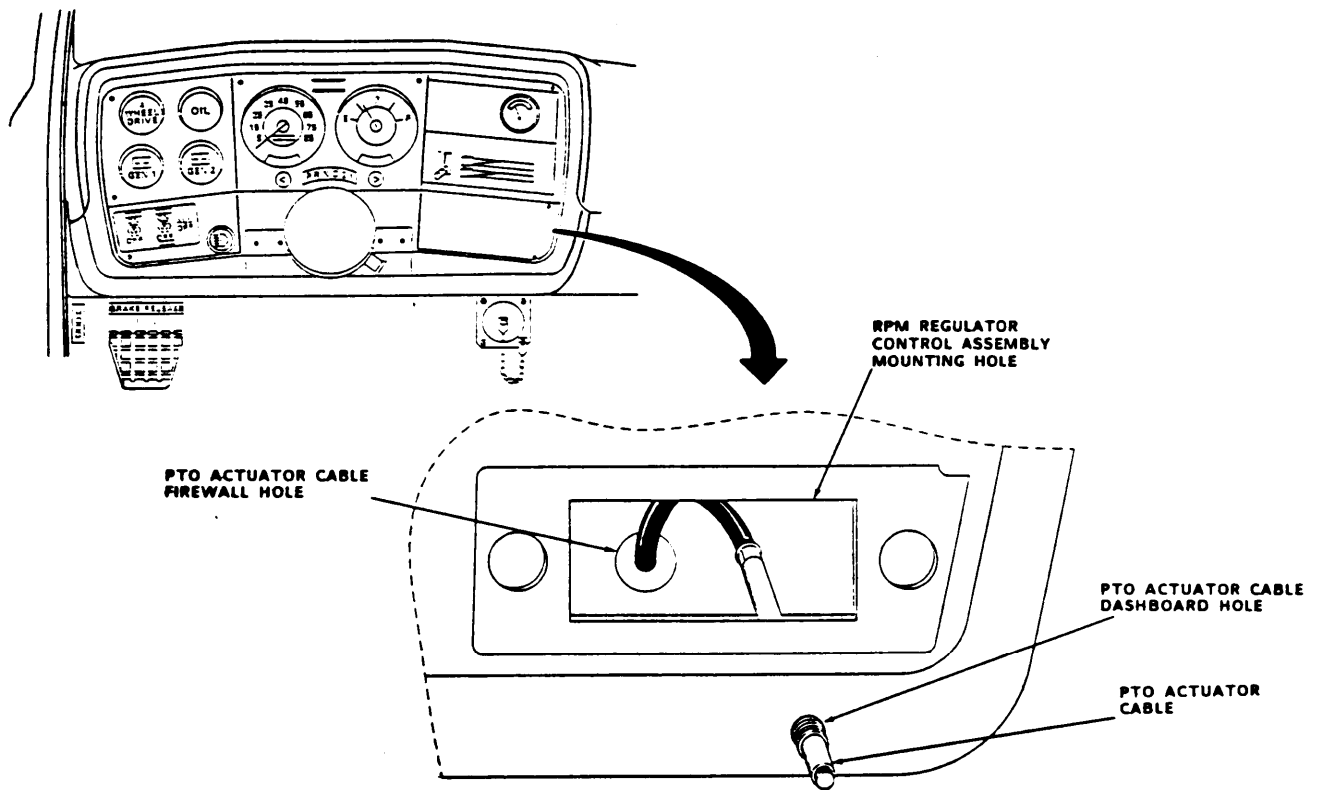

24. In truck cab, insert PTO actuator cable through hole in firewall and install through hole previously drilled in dashboard.

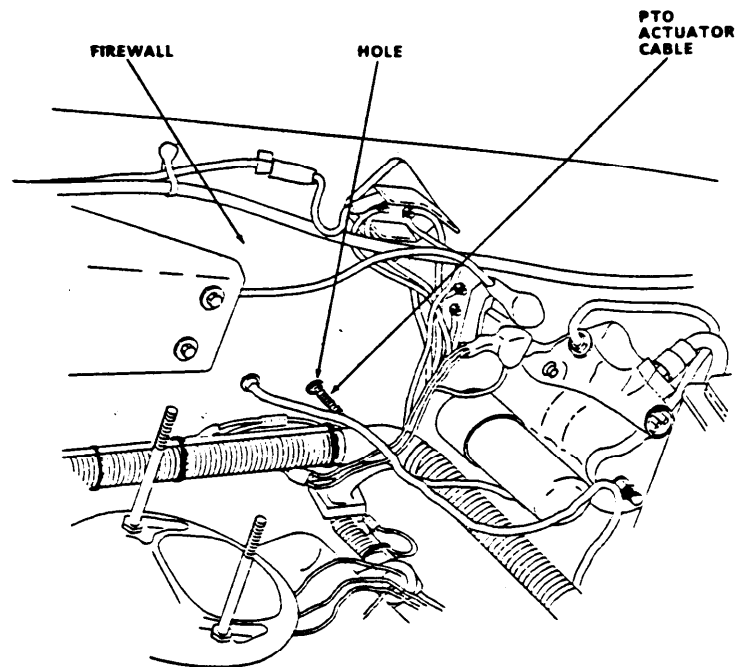

25. Place PTO actuator cable between engine and firewall towards PTO unit.

26. On PTO unit, place cable housing in mounting bracket on PTO assembly. Cable should have enough slack with no kinks to keep it from rubbing against engine or firewall.
27. Under dashboard, reinstall nut holding PTO actuator cable to dashboard. Using 3/4" combination wrench, hold cable housing. Using 3/4" combination wrench, tighten nut.
28. Install nut and knob on end of PTO cable using 9/16" combination wrench.
29. Pull PTO actuator cable out of housing about half way in truck cab.

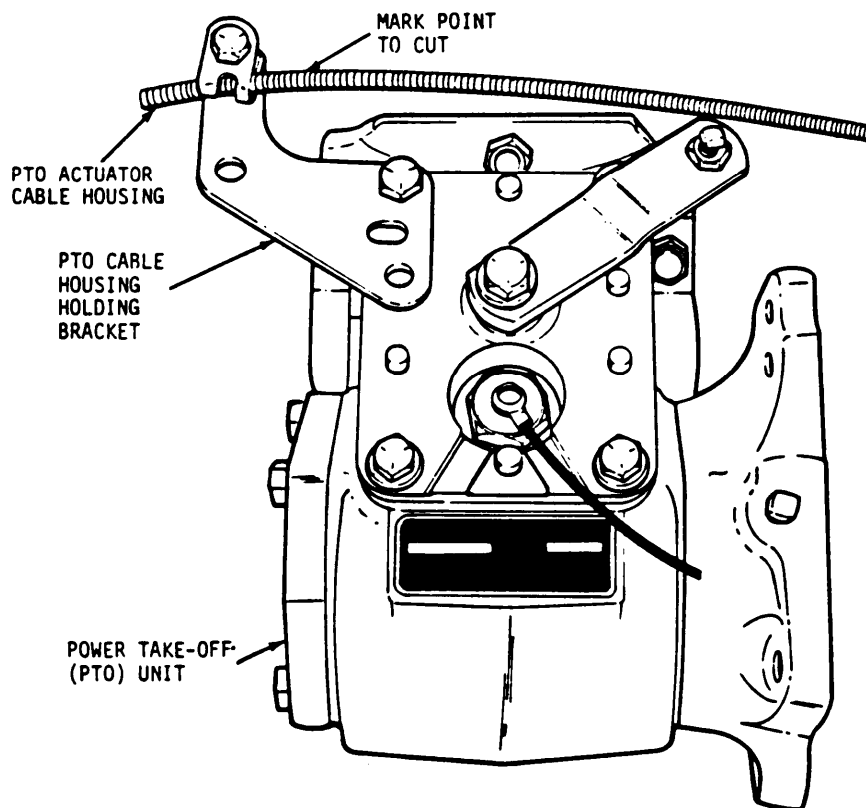

30. On PTO unit, remove cable housing from bracket. Mark point to cut on cable housing. Using diagonal cutting pliers, cut cable housing. Cable housing end should not be crimped closed after cutting.
31. Place cable housing in bracket on PTO unit. Using a 1/2" combination wrench, hold bolt. Using a 7/16" combination wrench, tighten nut onto bolt.

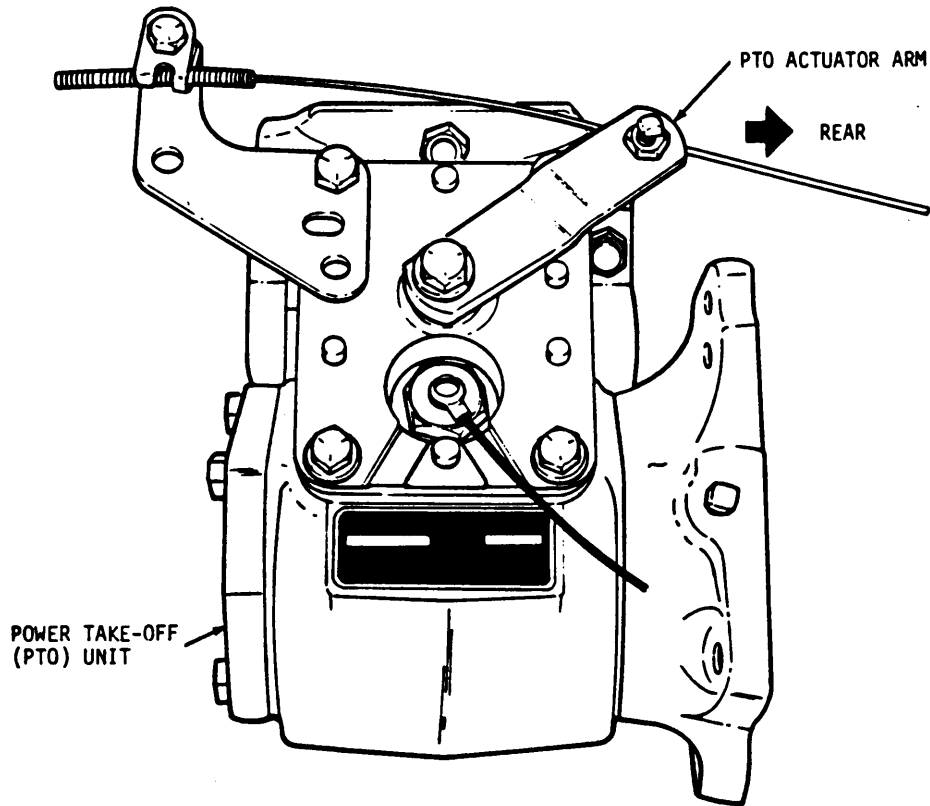

32. Rotate PTO actuator arm fully toward rear of truck.
33. In truck cab, push PTO control knob forward leaving about 1/4" between control knob and dashboard.

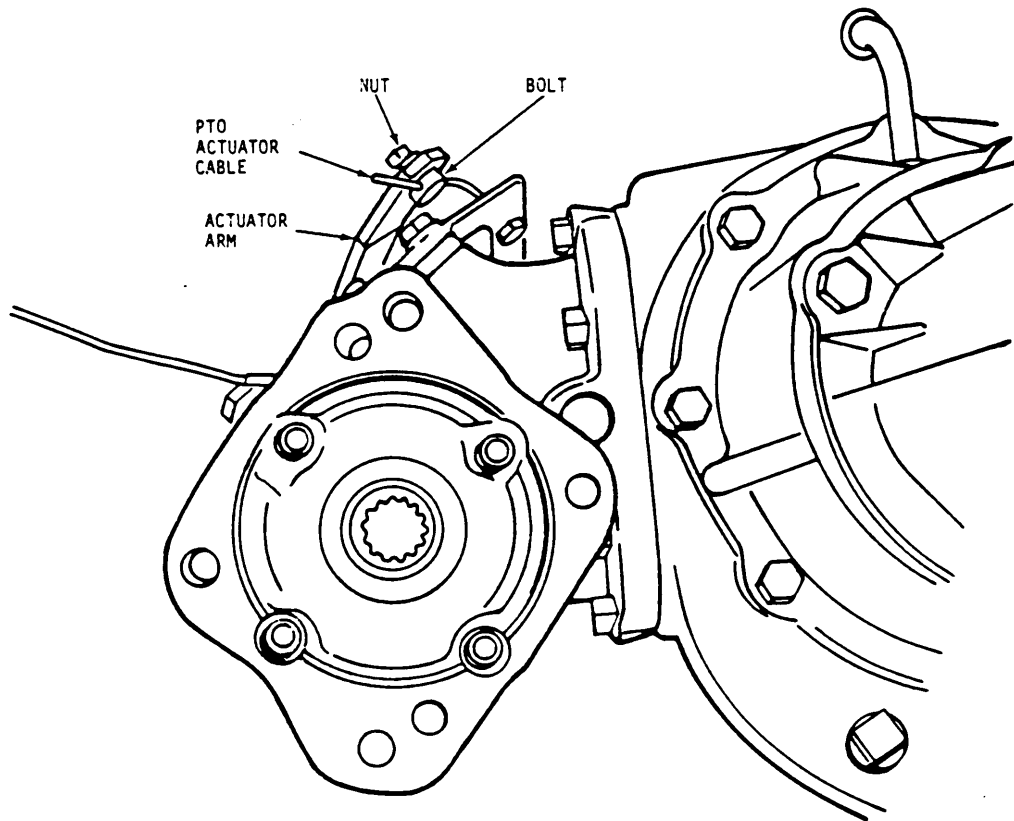

34. On PTO unit, place cable through hole in bolt at end of actuator arm. Using a 1/2" combination wrench, hold actuator arm bolt. Using a 1/4" combination wrench, tighten nut securing cable to bolt in actuator arm.
35. Cut off excess cable about one inch past actuator arm, using diagonal cutting pliers. Bend end of cable at a right angle to actuator arm using slip joint pliers.
36. In truck cab, engage and disengage PTO control knob to insure cable travel.
37. Inside engine compartment, apply RTV (MIL-A-46106, type 1) to hole where PTO actuator cable passes through firewall.

TACHOMETER

38. Using electric drill and 1/8" bit, drill out two rivets securing gauge panel to instrument panel.
39. Behind instrument panel cover, using 11/32" wrench, remove and retain two nuts securing wires to voltmeter terminals. Tag and remove wires. Remove voltmeter lamp and housing from voltmeter.
40. Using 3/8" combination wrench, remove and retain two nuts securing voltmeter bracket to mounting studs. Remove and retain voltmeter bracket.
41. Install voltmeter into right side of new gauge panel (item 28, C5110698-1). Secure voltmeter bracket onto mounting studs with two nuts. Using a 3/8" combination wrench, tighten nuts.
42. Install tachometer (item 61, C5110708-1) into left side new gauge panel (item 28, C5110698-1). Secure tachometer bracket to panel with two nuts. Using a 3/8" combination wrench, tighten nuts.

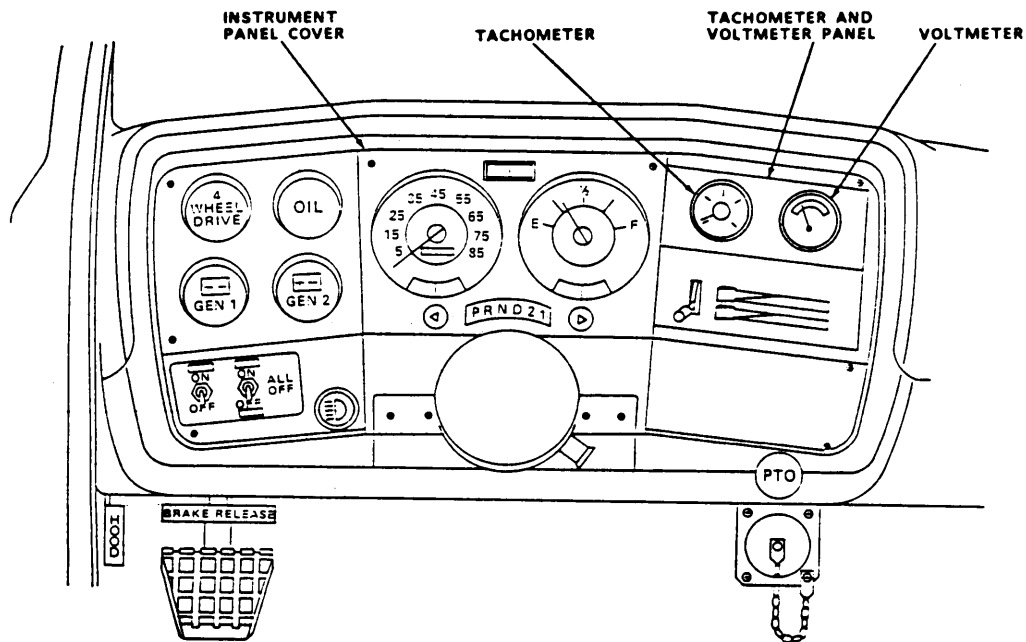

43. Splice W-67 cable to tachometer wires with splices (item 88, M7928/5-3 and item 89, M7928/5-4). Using crimping pliers, crimp splices. Reference figure 1 at back of this bulletin.
44. Reconnect wires to voltmeter terminals. Secure wires with two nuts. Using 11/32" combination wrench, tighten nuts. Reinstall lamp into voltmeter.
45. Install and tighten two screws (item 65, MS51957-29) and washers (item 87, AN960C6) securing gauge panel (item 28, C5110698-1) to instrument panel using NO. 1 cross tip screwdriver.

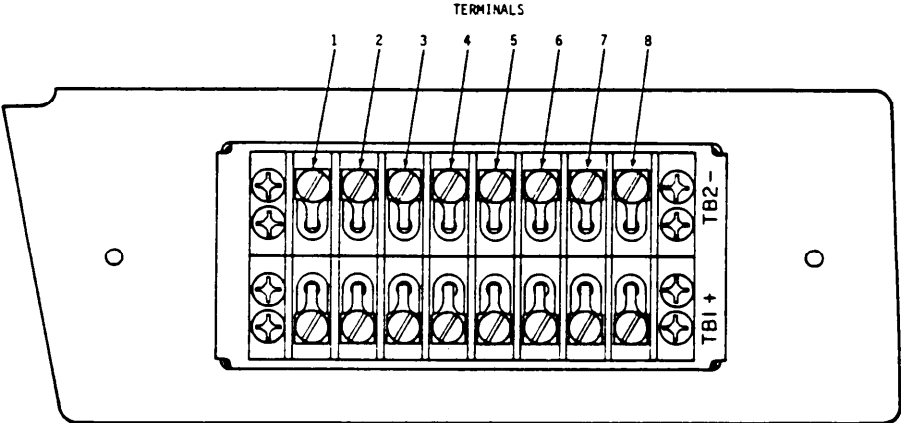

- 46. Route W67E1 and W67E2 through radio hole in dashboard. Connect W67E1 to TB2-3 and W67E2 to TB2-5 on rear of RPM regulator assembly (item 32, C5122577-1) using 3/16" flat tip screwdriver. Ensure W-67 cable (item 33, C5122564-1) is clear of heater controls in dashboard.

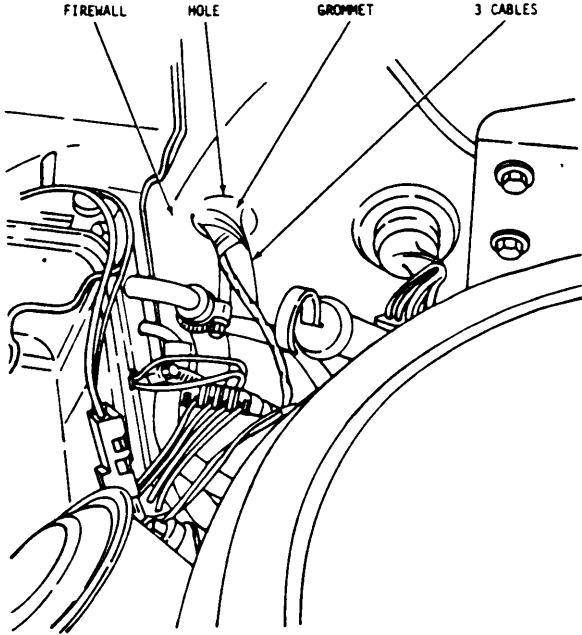

- 47. Install W-67 cable (item 33, C5122564-1) through hole in firewall and into engine compartment.

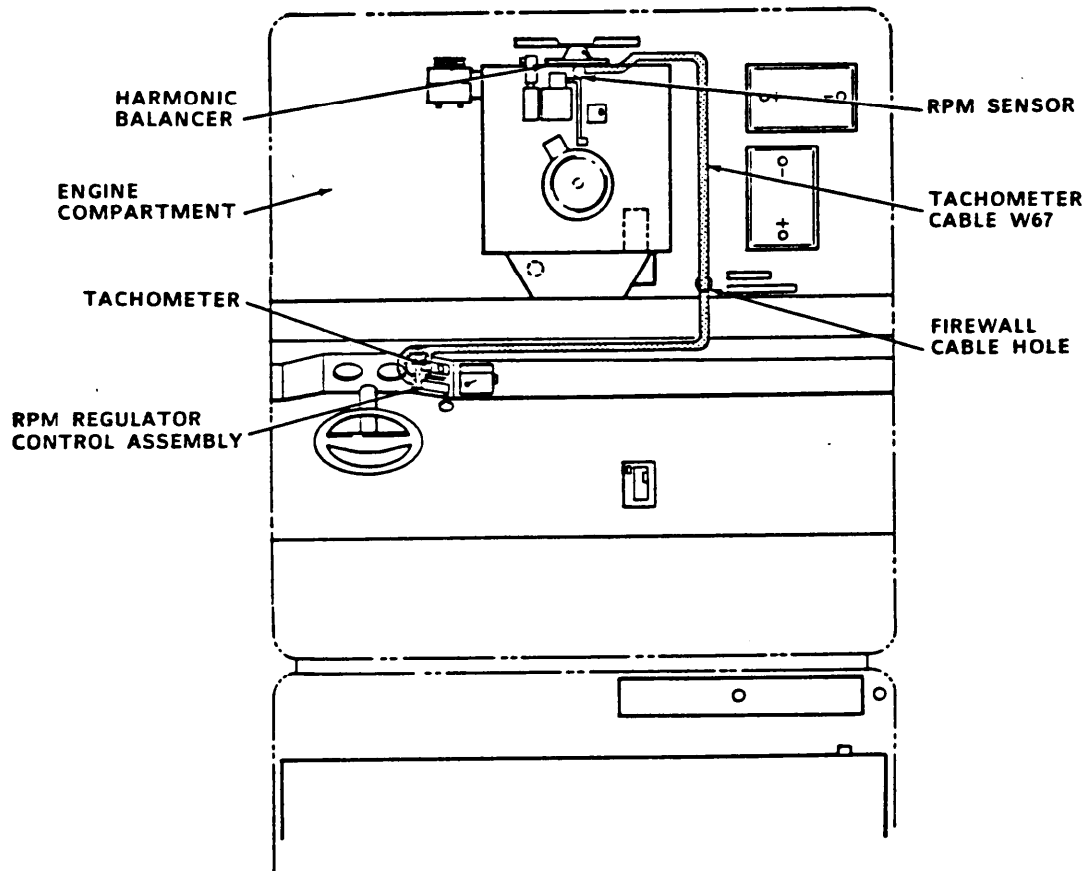

48. In engine compartment, route W-67 cable (item 33, C5122564-1) to sensor pickup at harmonic balancer.

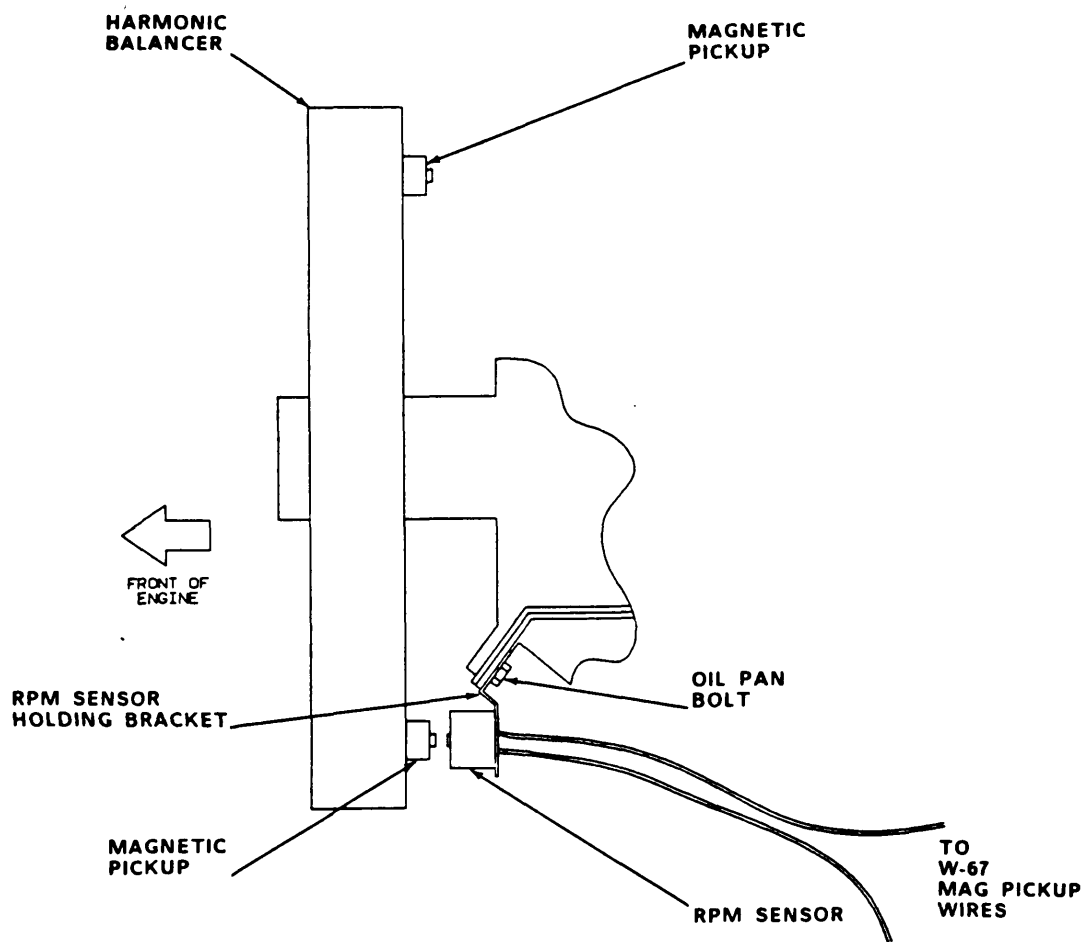

49. Apply thread lock (MIL-S-22743, grade JV) on the threads of the magnetic pickups.
50. On harmonic balancer, install magnetic pickups at opposite holes using 3/16" flat tip offset screwdriver.
51. Strip insulation from ends of W67 MAG PICKUP and RPM sensor wires.
52. Connect each end of RPM sensor wire to each W67 MAG PICKUP wire with splice (item 88, M7928/5-3). Using crimping tool, crimp wire splices.
53. On oil pan, remove and retain bolt closest to harmonic balancer using 3/8" drive ratchet handle, 6" extension, and 10 MM socket.
54. Install RPM sensor holding bracket (item 34, C5122610-1) and secure with bolt using 3/8" drive ratchet handle, 6" extension, and 10 MM socket.
55. Insure magnetic pickups on harmonic balancer pass in front of RPM sensor.

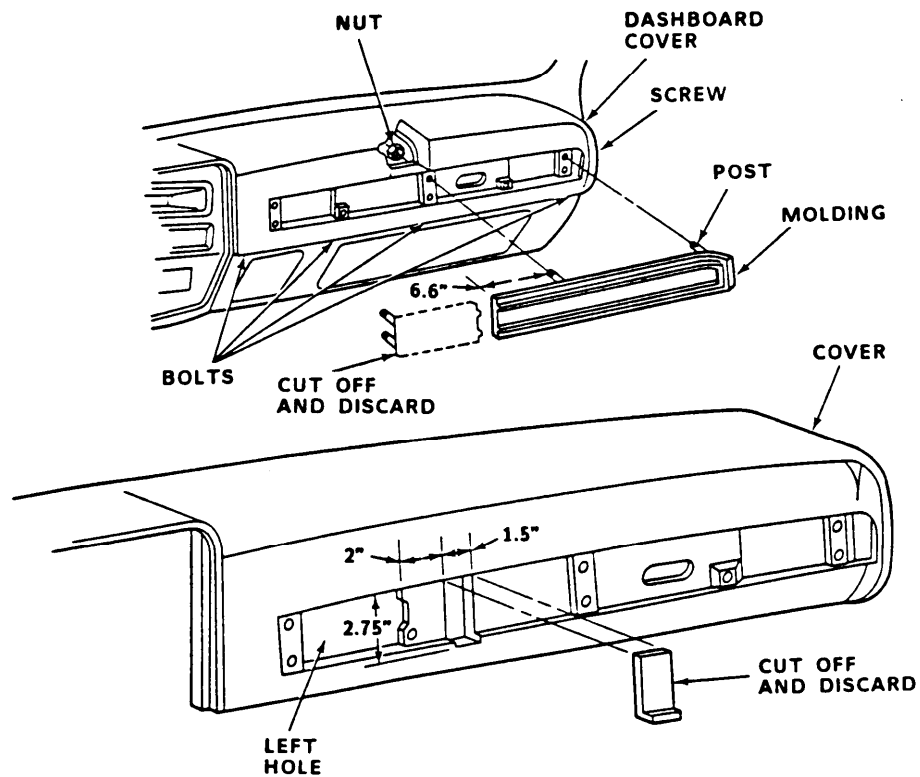

56. In truck cab, remove and retain four bolts and one screw securing dashboard cover using 9/32" nut driver and NO. 2 cross tip screwdriver. Remove dashboard cover. Refer to TM 9-2320-289-34.
57. Using 3/8" combination wrench, remove and retain nut securing instrument panel molding to dashboard cover.
58. Measure 6-5/8" left of center post on molding. Cut molding using saber saw.
59. Measure 2" right from right side edge of left hole and mark a vertical line. Measure 1-1/2" right from the vertical line, and mark another vertical line. Measure 2-3/4" down from upper edge where molding is attached to dashboard cover and mark a horizontal line. Cut a new opening where marked using saber saw.
60. Reinstall instrument panel molding onto dashboard cover. Secure molding with a nut. Using a 3/8" combination wrench, tighten nut.

REMOTE RADIO CONTROL MOUNTING BRACKET (cont.)

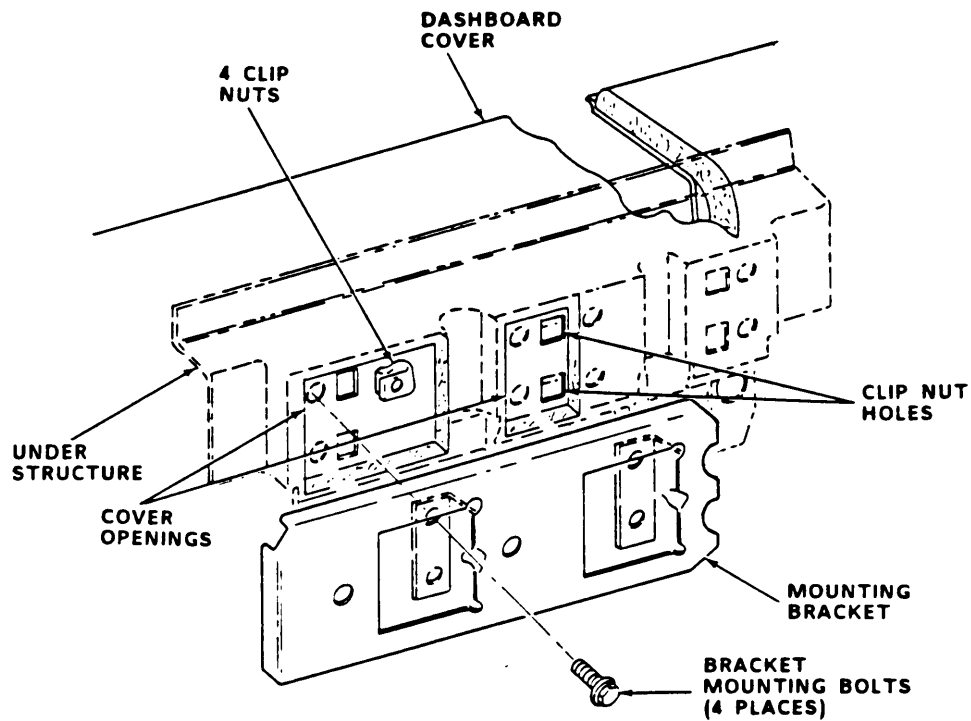

61. Install four clip nuts (item 52, C5131353-1) in holes on dashboard understructure. Clip nuts must be accessible through new opening and existing opening on left side of dashboard cover.
62. Reinstall four bolts and one screw holding dashboard cover using 9/32" nut driver and NO.2 cross tip screwdriver.
63. Install mounting bracket for remote radio control (C-2298/VRC) with four bolts and secure using 3/8" drive ratchet handle, 6" extension, and 7/16" socket.

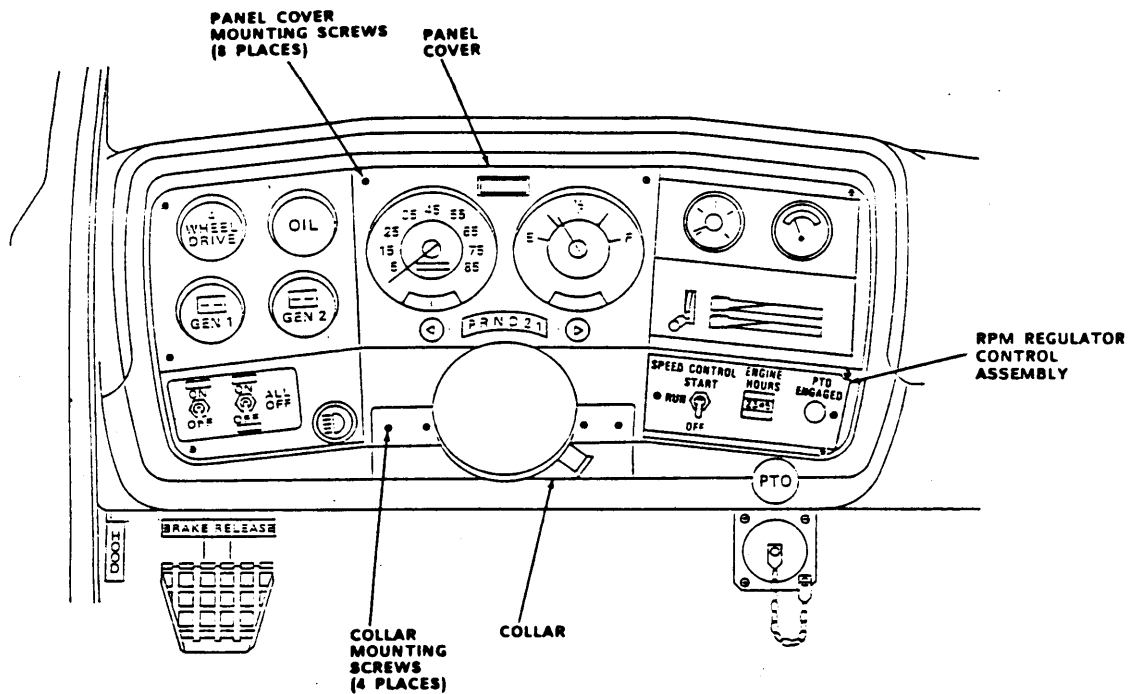
REMOTE RADIO CONTROL MOUNTING BRACKET (cont.)

64. Move instrument panel cover into place and reinstall two warning lights. Turn light housings 1/4 turn counterclockwise to lock into panel.
65. Reinstall eight screws securing instrument panel cover and four screws securing collar under steering column and tighten using NO. 2 cross tip screwdriver.

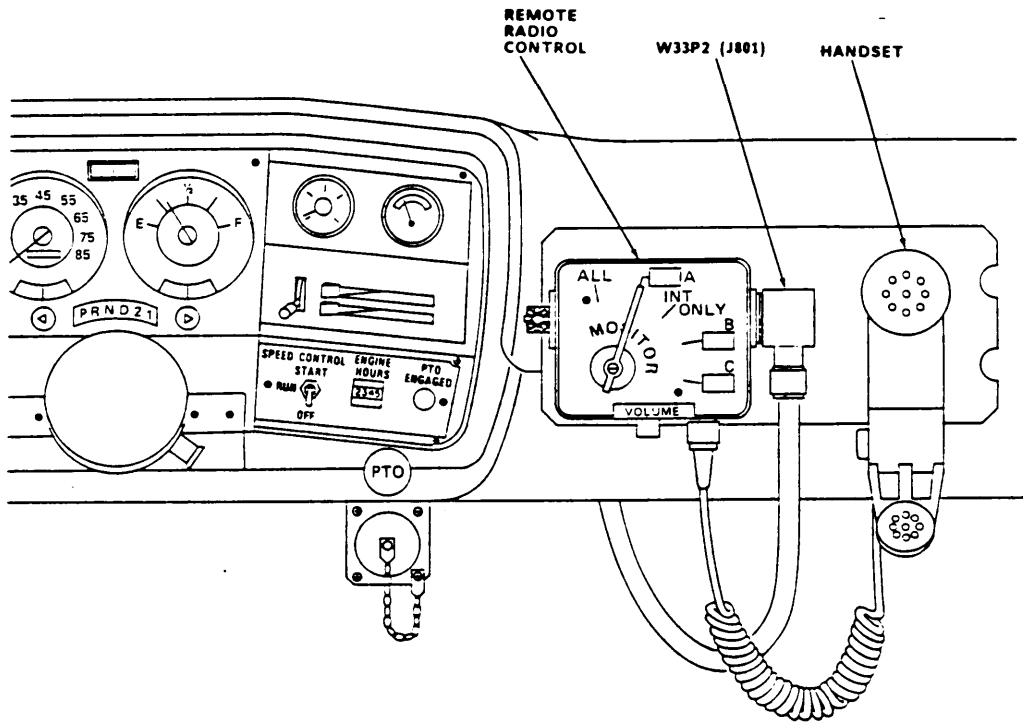

66. Install remote radio control (C2298/VRC) on mounting bracket and secure with bolts using a 3/8" drive ratchet handle, 3" extension, 1/2" socket, and 1/2" combination wrench.
67. Install handset (H250/U) on remote radio control (C2298/VRC).

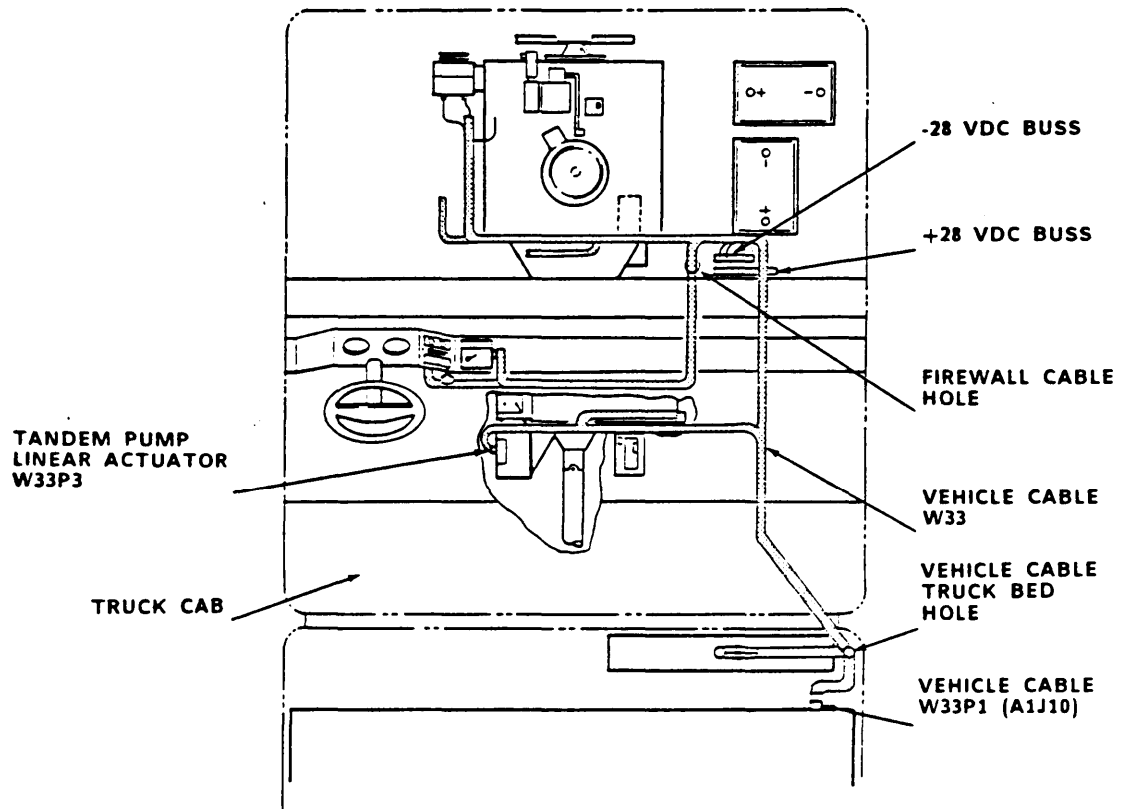

68. Place W-33 vehicle cable (item 29, C5110787-1) through existing hole in the right front corner of the floor of the truck bed. Make sure existing grommet is in good condition. Route W-33 vehicle cable (item 29, C5110787-1) under vehicle along upper vehicle frame, and up through engine compartment to firewall.

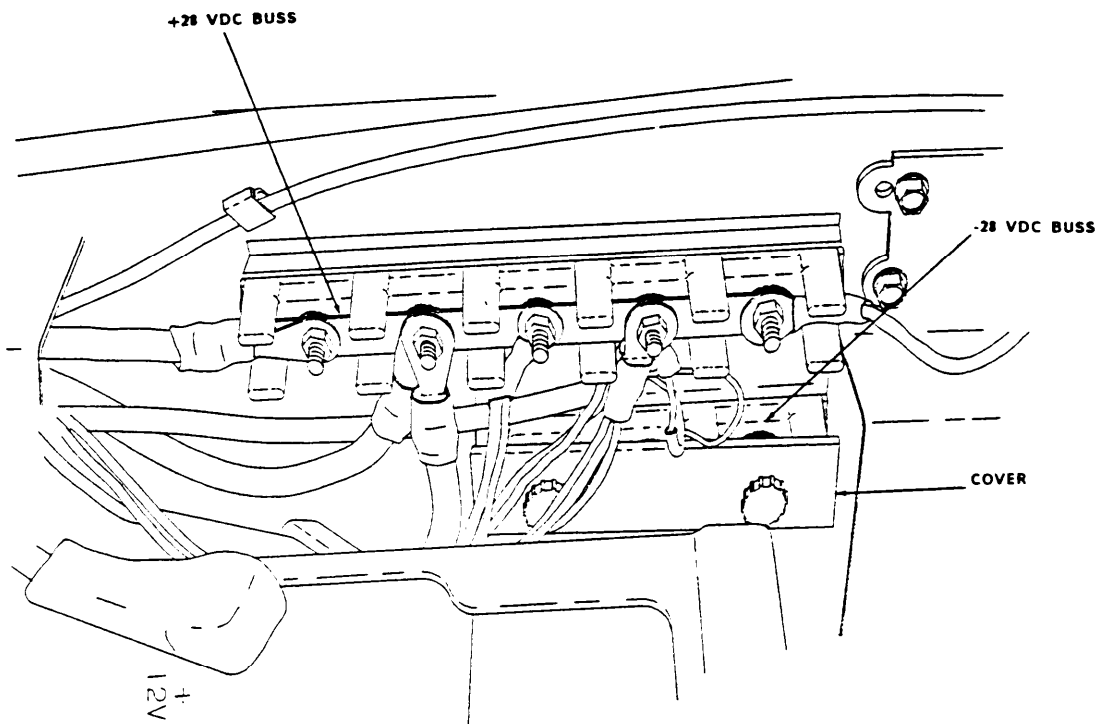

69. Remove covers from TB1 (+28 VDC BUSS) and TB2 (-28 VDC BUSS) on engine compartment firewall.
70. Locate portion of the W-33 vehicle cable that is labeled 28V VEHICLE PWR. Connect the WHITE wire to TB1 and the BLACK wire to TB2 on the firewall using 3/8" drive ratchet handle, 6" extension, and 1/2" socket.
71. Route W-33P2 (A20A1J801) and field current relay wire (item 29, C5110787-1) through hole in firewall to remote radio control (C2298/VRC).

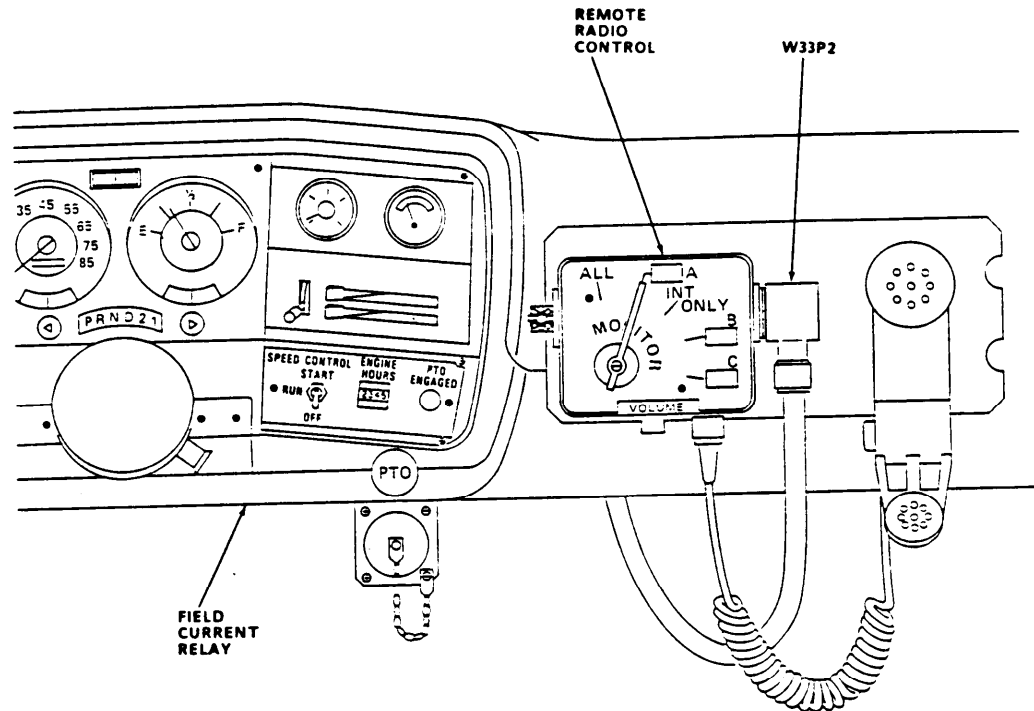

NOTE

Most wires are shielded. Ensure that the shielding is stripped and only the center conductor is connected to the solder cups and/or crimp terminal.

72. In truck cab, install five wires of W-33 cable to pin terminals of W33P2 according to bandmarkers. Solder five wires to proper pin terminals using 45 watt soldering iron.
73. Connect W33P2 to J801 of remote radio control (C2298/VRC).
74. Remove and retain two bolts securing relay mounting bracket and diagnostic equipment connector under dashboard using 7/16" combination wrench.
75. Cut brown and white striped wire connected to relay on right using diagonal cutting pliers.
76. Strip insulation from both ends of the brown and white stripped wire.
77. Splice both ends of the brown and white stripped wire to W33 FIELD CUR RELAY wire with splices (item 89, M7928/5-4). Using crimping tool, crimp wire splices.
78. Reinstall relay mounting bracket and diagnostic equipment connector under dashboard with two bolts using 7/16" combination wrench.

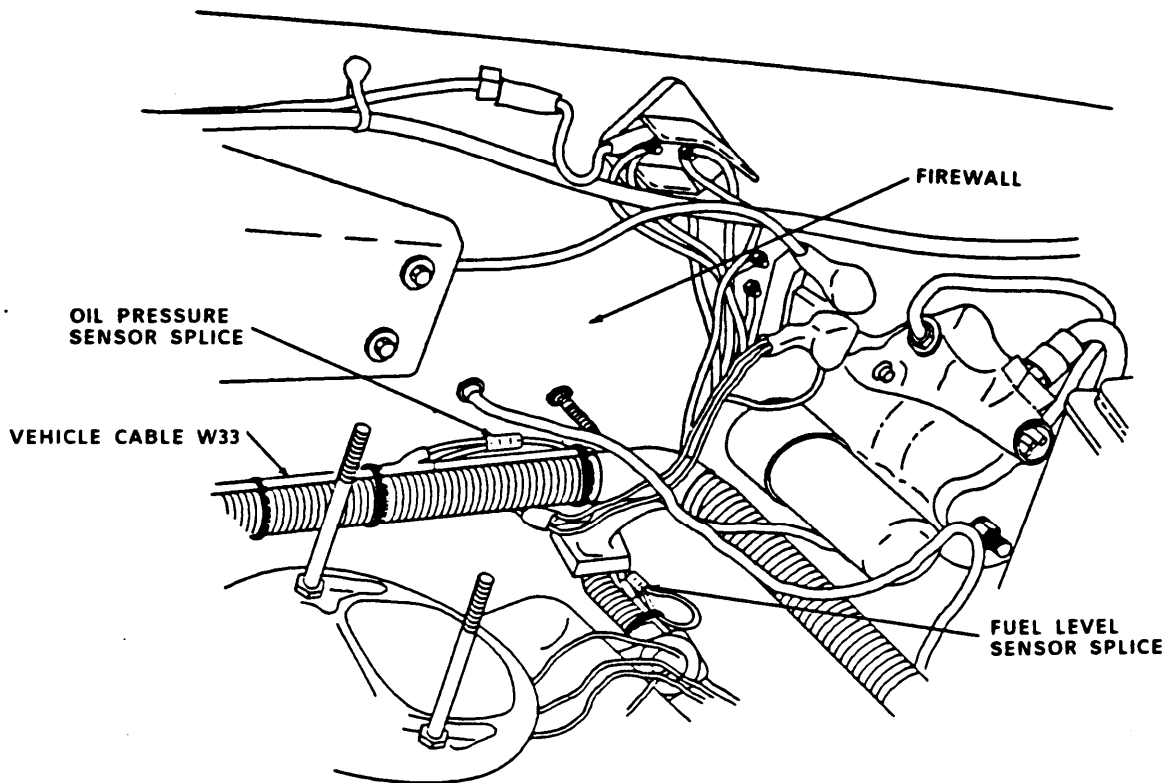

NOTE

For truck wiring diagrams, refer to truck technical manuals, TM 9-2320-289-20 or TM 9-2320-289-34.

79. In engine compartment, cut oil pressure sensor wire on top rear of engine using diagonal cutting pliers.
80. Strip insulation from both ends of oil pressure sensor wires.
81. Connect both ends of the oil pressure sensor wires to W33 OIL PRESS wire with splice (item 89, M7928/5-4) using crimping tool.
82. Cut fuel level sensor wire located at rear of engine using diagonal cutting pliers.
83. Strip insulation from both ends of the fuel level sensor wires.
84. Connect both ends of the fuel level sensor wires to W33 FUEL SENSOR wire with splice (item 89, M7928/5-4) using crimping tool.

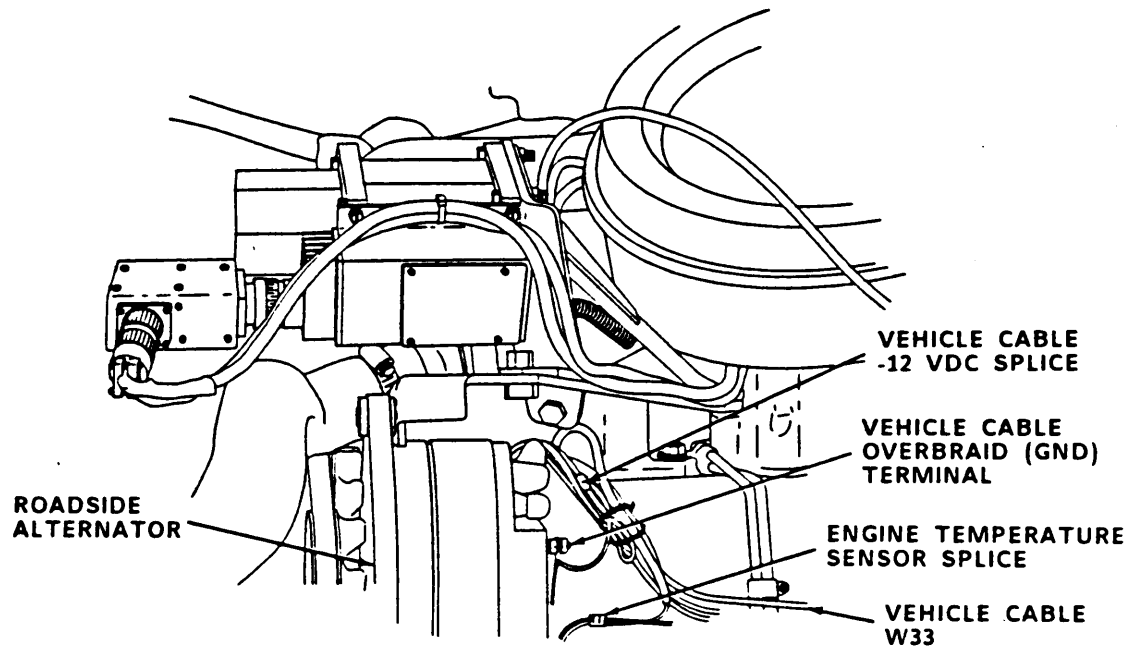

85. Cut engine temperature sensor wire located below roadside alternator using diagonal cutting pliers.
86. Strip insulation from both ends of the engine temperature sensor wires.
87. Connect both ends of the engine temperature sensor wires to W33 ENG TEMP wire with splice (item 89, M7928/5-4) using crimping tool.
88. Cut -12V alternator wire located behind roadside alternator using diagonal cutting pliers.
89. Strip insulation from ends of -12V alternator wire.
90. Connect ends of -12V alternator wire to W33 12V ALTNTR (NEG) wire with splice fastener (item 89, M7928/5-4) using crimping tool.
91. Using 10 mm wrench, connect W33E2 to ground terminal post on roadside alternator. Tighten nut on ground terminal post.
92. Using cable ties, secure W-33 vehicle cable (item 29, C5110787-1) away from exhaust manifold along with existing routed wires and fasteners.

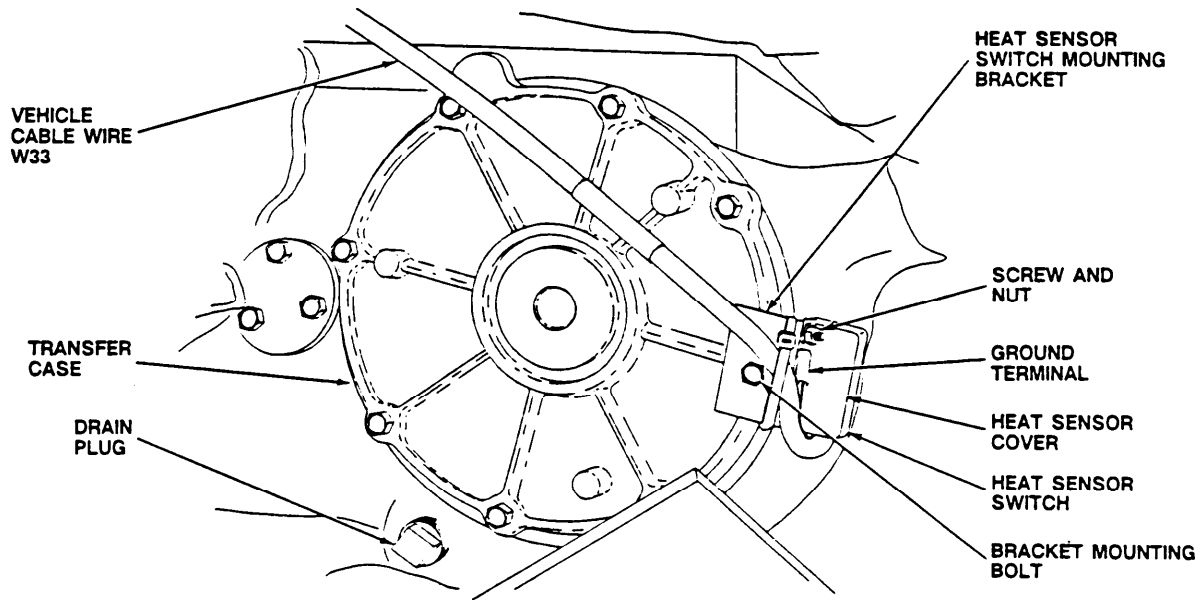

93. Solder terminal lug (item 71, MS25036-148) on ground wire (item 72, M16878/4BCB9) to heat sensor switch terminal using 45 watt soldering iron.
94. Solder W-33 DRIVE TRAIN shielded wire to heat sensor switch terminal using 45 watt soldering iron.
95. Insert grommet (item 70, MS35489-4) in heat sensor cover.
96. Place heat sensor cover (item 35, C5122611-1) on mounting bracket. Place ground wire terminal lug (item 71, MS25036-14B) on one screw. Tighten screws (item 66, MS24693C3), nuts (item 68, NAS671C4), and washers (item 67, NAS1640-4) using NO.1 cross tip screwdriver and 3/16" combination wrench.
97. Under truck bed, route W-33 cable (item 29, C5110787-1) over curbside frame of vehicle.
98. Remove and retain bolt located on the right rear of the transfer case using 3/8" drive ratchet handle, 6" extension, and 9/16" socket. Install the mounting bracket on the transfer case and secure with bolt.
99. Check fluid level of transfer case and fill (refer to TM 9-2320-289-20) if necessary.

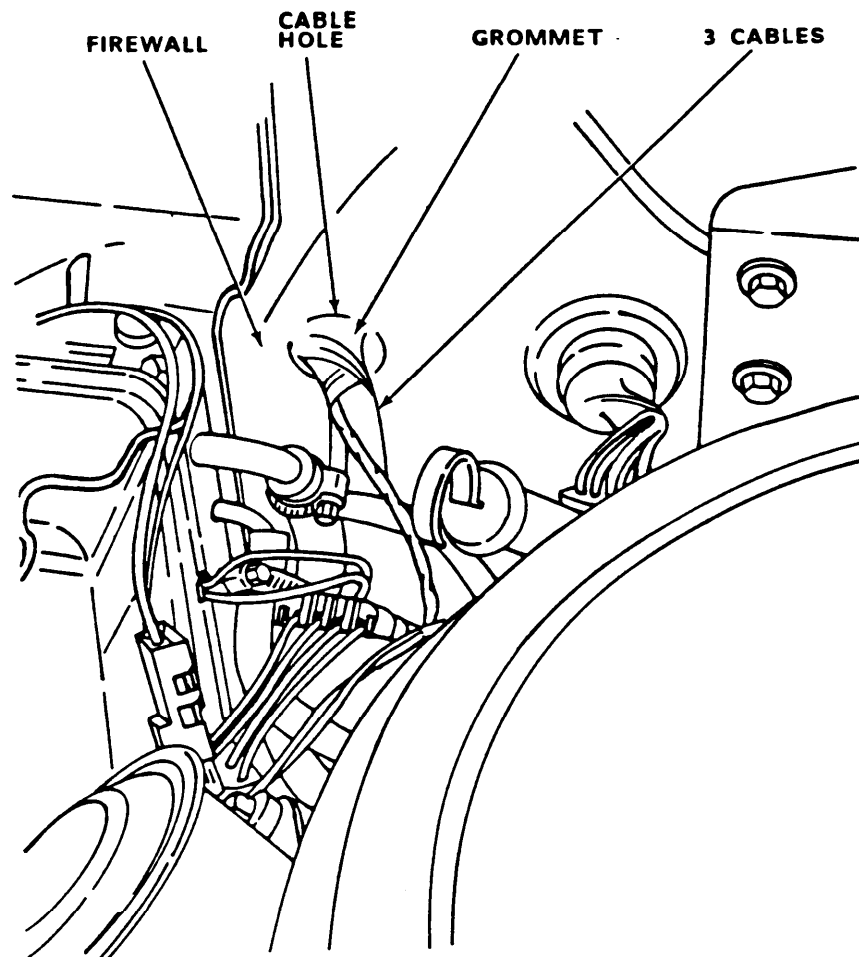

100. In engine compartment, route W-65 cable (item 31, C5118955-1) (TB1 and TB2 terminal connectors and W65 S1 and S2 wires) through hole in firewall.
101. Pull W-65 cable (item 31, C5118955-1) (TB1 and TB2 terminal connectors and W65 S1 and S2 wires) through firewall into truck cab. Route W-65 cable (S1 and S2 wires) behind dashboard and under floor mat to transfer case shift lever assembly.

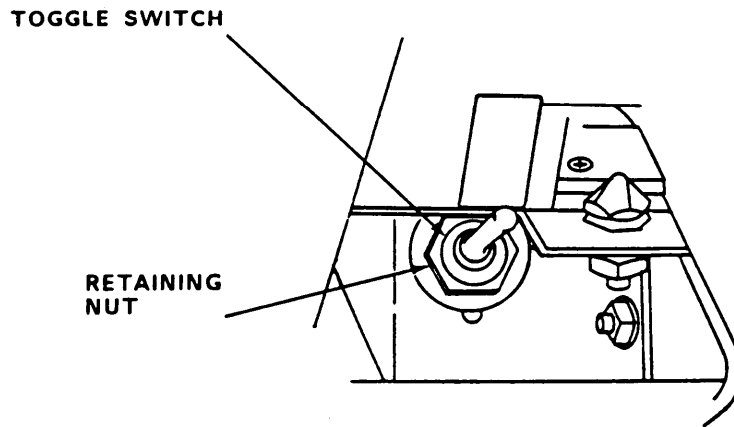

102. Remove and retain retaining nut from toggle switch barrel using 9/16" combination wrench. Remove switch from mounting hole in lockout assembly housing.
103. Connect W65S1 and W65S2 to transfer case lockout switch (terminals 1 and 2) using 3/16" flat tip screwdriver. Secure W-65 cable (item 31, C5118955-1) with tiedowns (item 73, MS3367-2-0) using tiedown tool.

NOTE

The spring-loaded toggle switch is a normally-open switch. Ensure switch toggle lever is in an upward position when door is open. For proper operation, listen for an audible click when closing door.

104. Place switch through mounting hole in housing. Reinstall retaining nut and tighten using 9/16" combination wrench.

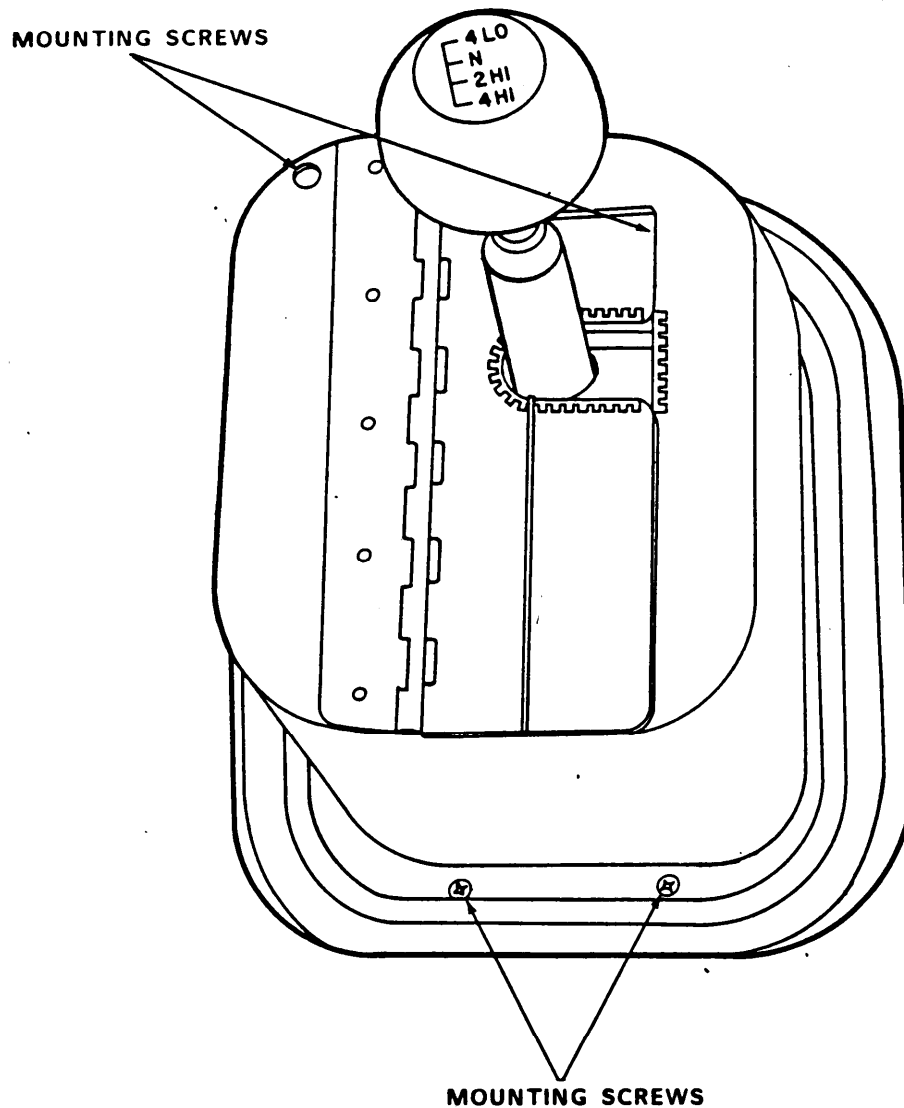

105. Using a no.2 cross-tip screwdriver, remove and retain four escutcheon plate screws from transfer case shift lever assembly.

NOTE

To install left front screw in following step, insert screw through hole at corner of lockout assembly.

106. Install lockout assembly on truck floor and secure with four screws using NO.2 cross tip screwdriver.
107. Pull W-65 wire terminals through instrument panel opening.

NOTE

There are two wires on terminals A3TB2-3 and A3TB2-5.

108. Using 3/16" flat tip screwdriver, connect six wires from W-65 cable (item 31, C5118955-1) (TB1-1 through TB1-6) to terminal block TB1 of RPM regulator (item 32, C5122557-1). Observe wire band markers for proper installation.
109. Using 3/16" flat tip screwdriver, connect six wires from W-65 cable (item 31, C5118955-1) (TB2-1 through TB2-6) to terminal block TB2 of RPM regulator (item 32, C5122557-1). Observe wire band markers for proper installation.

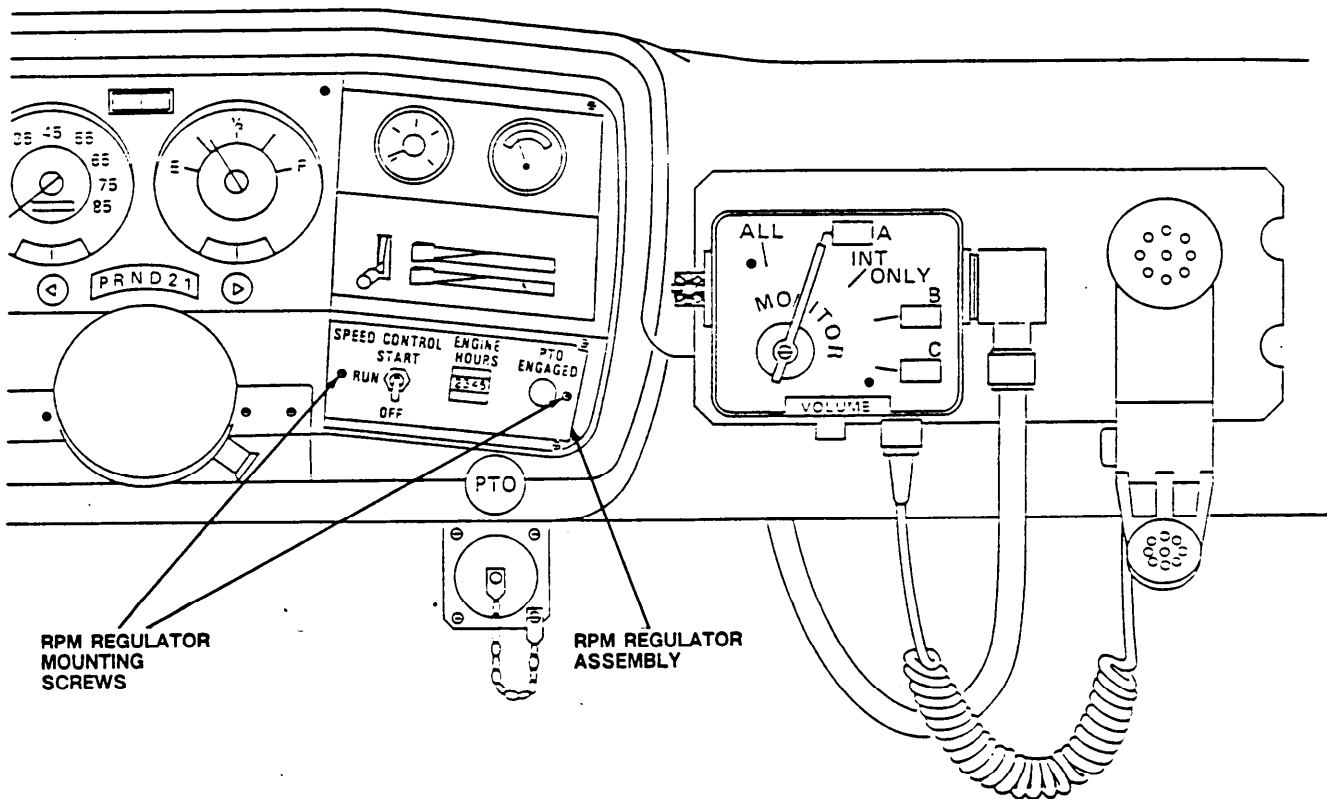

110. On dashboard, install two U-nuts (item 51, C5131383-1) to RPM regulator mounting holes.
111. Install RPM regulator assembly (item 32, C5122557-1) and secure with two screws (item 50, MS51959-70B) using NO.2 cross tip screwdriver.

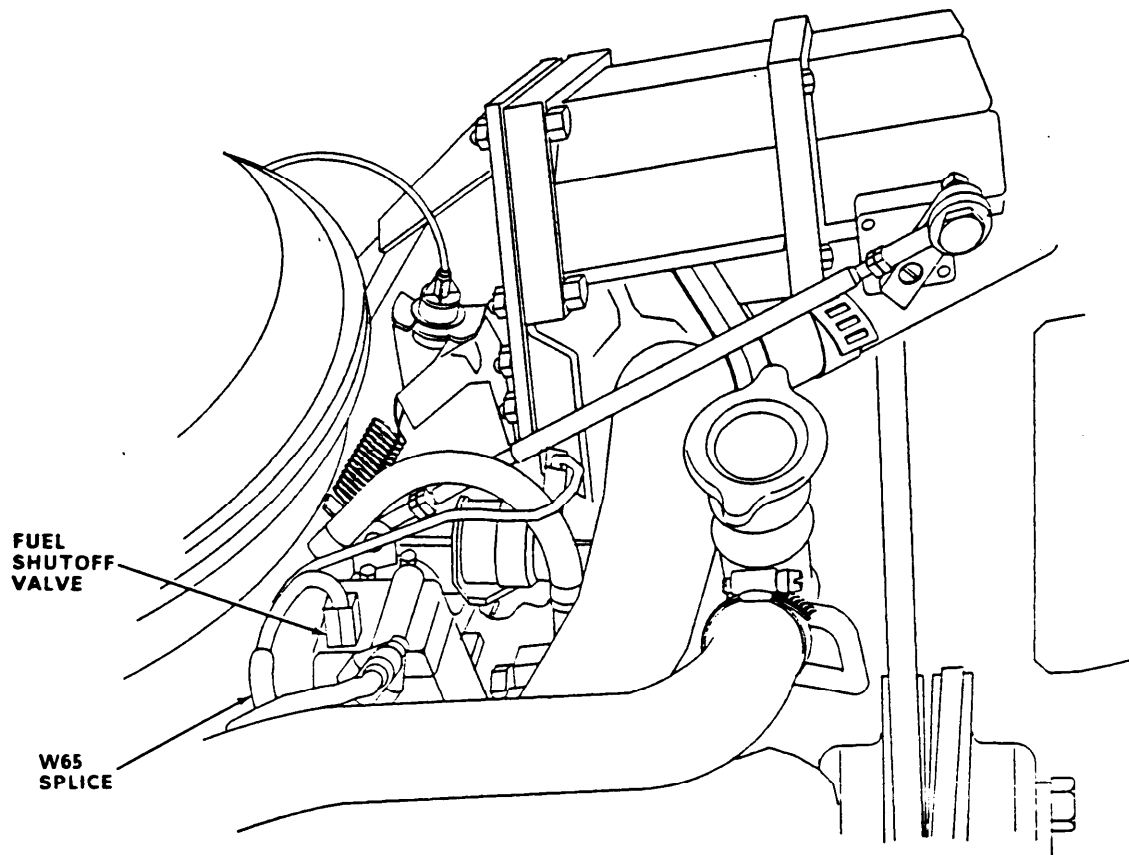

112. Cut fuel shutoff valve wire located at front of engine using diagonal cutting pliers.
113. Strip insulation from ends of fuel shutoff valve wire.

NOTE

Most wires are shielded. Ensure that the shielding is stripped and only the center conductor is connected to the solder cups and/or crimp terminal.

114. Connect ends of fuel shutoff valve wires to W65 FUEL SHUTOFF non-shielded wire with splice (item 90, M7928/5-5) using crimping tool.

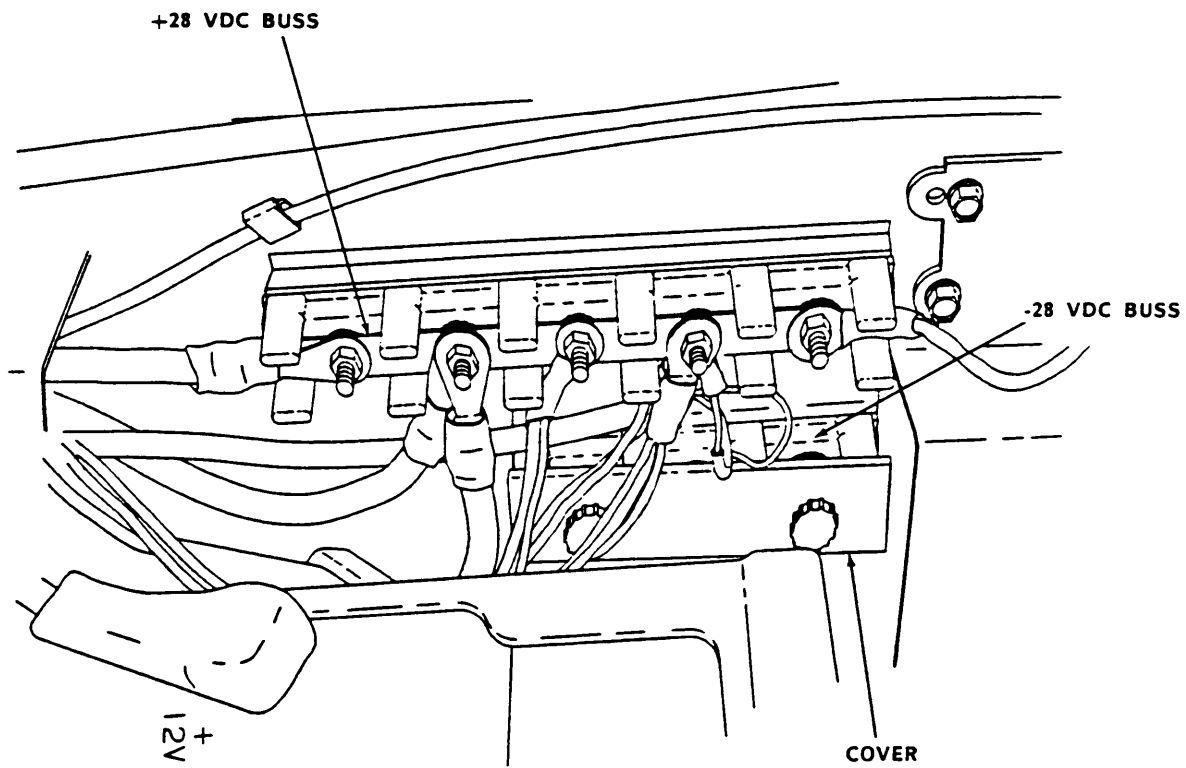

115. Connect W65E1 to TB1 (+28 VDC BUSS) and W65E2 to TB2 (-28 VDC BUSS) on the firewall using 3/8" drive ratchet handle, 6" extension, and 1/2" socket.
116. Reinstall covers on TB1 and TB2 on engine compartment firewall.

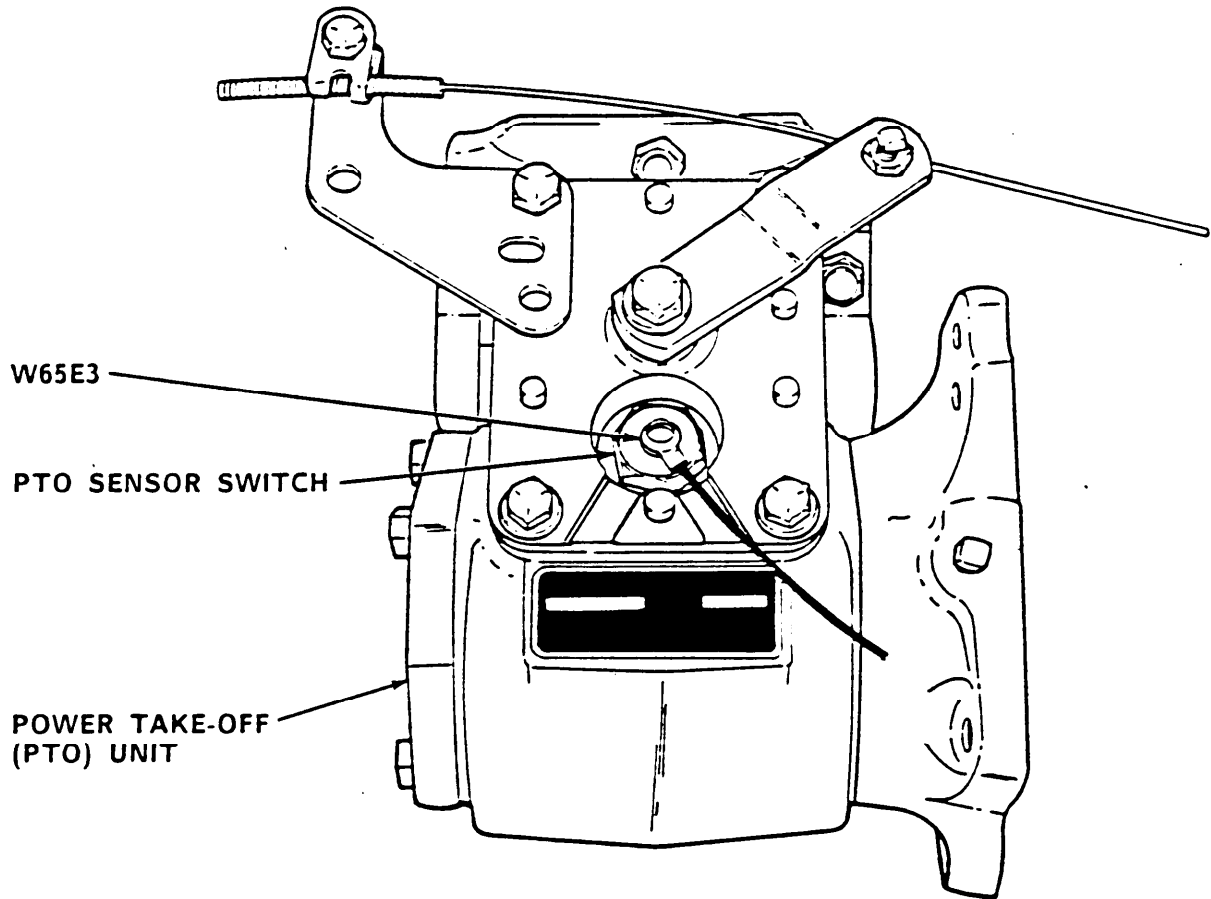

117. On PTO unit, connect W65E3 to PTO sensor switch using 1/4" flat tip screwdriver with 1 1/2" shaft. Secure W-65 cable (item 31, C5118955-1) with tiedowns (item 73, MS3367-2-0) using tiedown tool.
118. Apply RTV (MIL-A-46106, type 1) around cable hole in firewall.

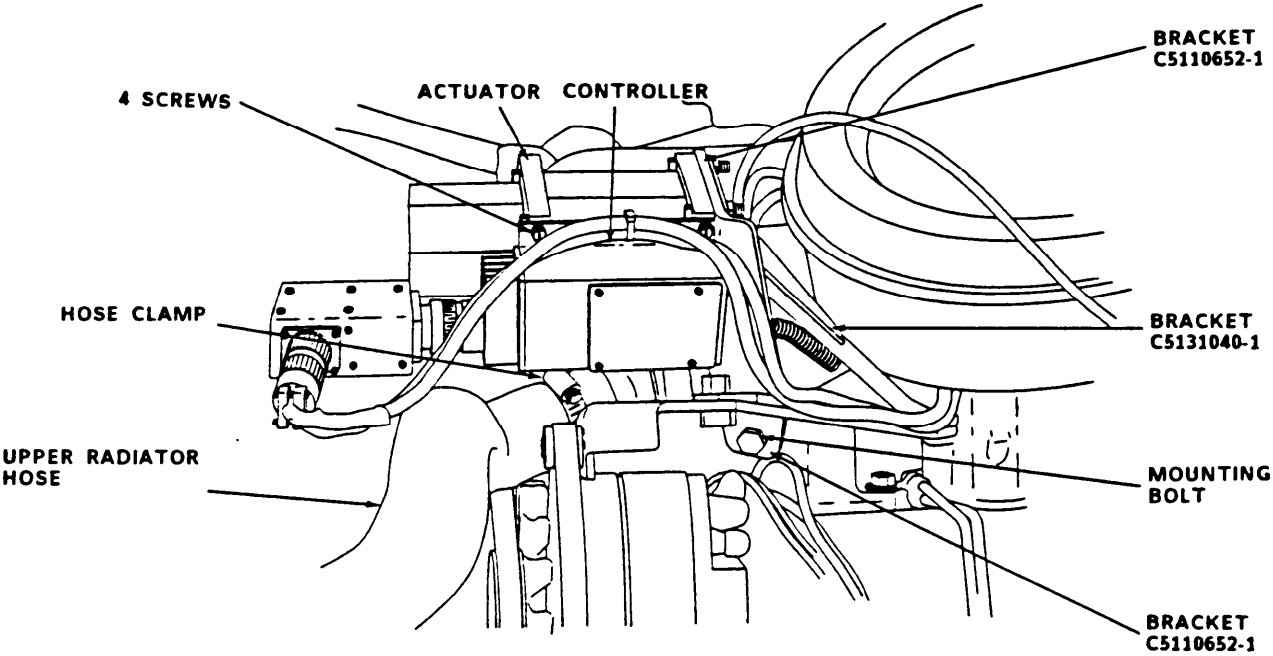

- 119. Remove air cleaner assembly from engine. Using cloth, cover intake manifold opening.
- 120. Apply thread lock (MIL-S-22473, grade C) to four screws from speed control actuator and controller units. Install four screws and washers and tighten using 1/4" flat tip screwdriver.

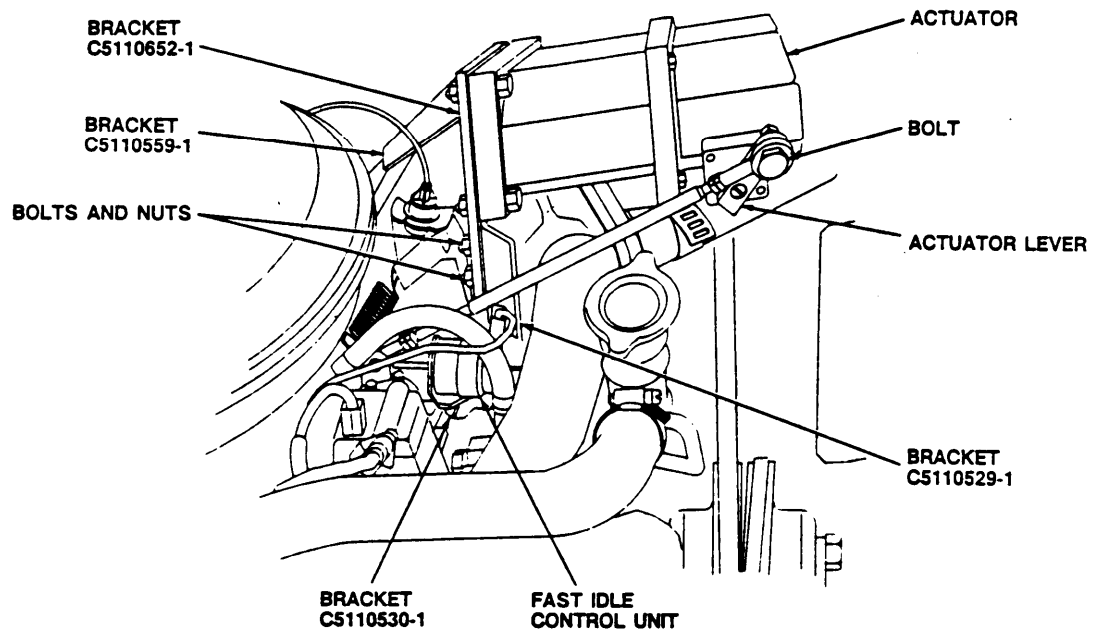

121. Using 5/16" combination wrench and NO. 2 cross tip screwdriver, remove fast idle control unit from throttle cable bracket. Attach bracket (item 25, C5110530-1) to throttle cable bracket.
122. Secure fast idle control unit to new bracket with screws (item 68, MS51958-62; item 78, MS24693C272; item 79, MS51958-64) and nut (item 80, NAS671C10).

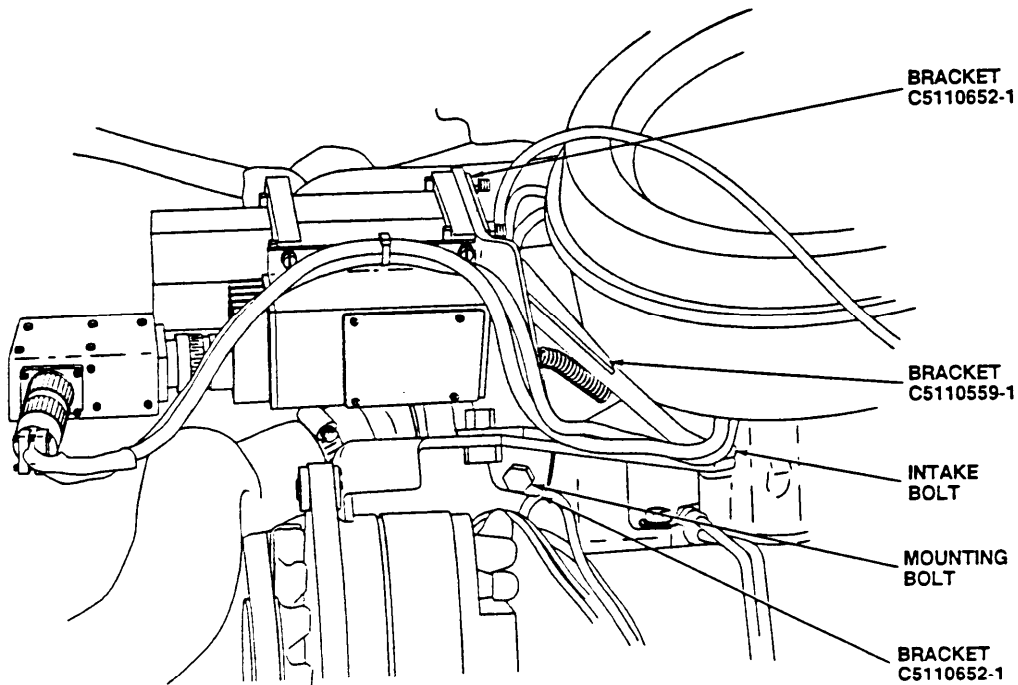

123. Using two 1/2" combination wrenches, loosely connect bracket (item 27, C5110652-1) to bracket next to roadside alternator with two bolts (item 62, MS35307-333), nuts (item 64, MS51971-2), lock washers (item 63, NAS1640-516).
124. Using 15mm socket, remove forward nut on second intake port bolt. Position bracket (item 26, C5110559-1) over bolt and thread on lock nut (item 69, C5131106-1) from installation kit. Using 17mm socket, tighten nut. Other end of bracket should be aligned with top holes in bracket (item 27, C5110652-1).

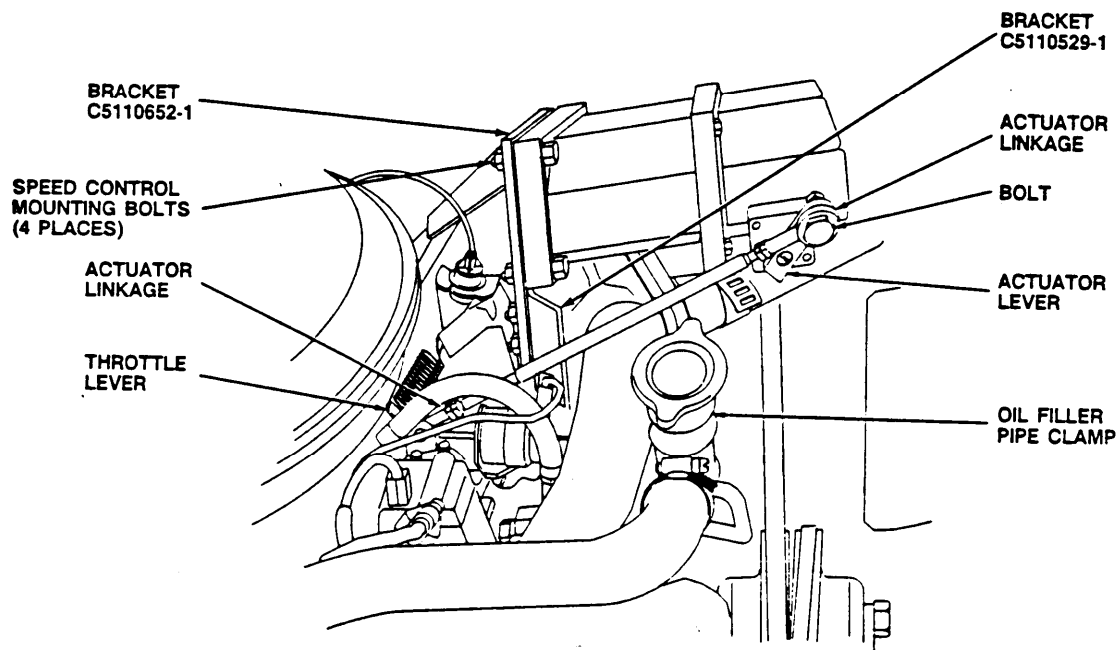

125. Using two 1/2" open end wrenches, remove and retain nut from oil filler pipe clamp. Attach bracket (item 24, C5110529-1) to oil filler pipe clamp and tighten nut using 1/2" combination wrench.
126. Using two 1/2" combination wrenches, loosely connect bracket (item 24, C5110529-1) to bracket (item 27, C5110652-1) with two bolts (item 75, MS35307-309), nuts (item 43, MS51971-1), flat washers (item 45, AN960C416), and lock washers (item 47, NAS1640-416). Tighten all hardware loosely installed in previous steps.
127. Using 1/8" and 5/32" hex key wrenches, attach actuator linkage to vehicle throttle lever.
128. Install bolt (item 104, MS35309) on actuator lever (item 91, C5131375-1) and tighten using 3/8" drive ratchet handle, 7/16" socket, and 7/16" combination wrench.
129. Connect actuator linkage and throttle lever together. Tighten lock nut on actuator linkage using 3/8" combination wrench. Tighten lock nut on throttle lever using 7/16" combination wrench.
130. Using 5/32" hex key wrench, attach modified actuator lever to speed control actuator arm shaft.

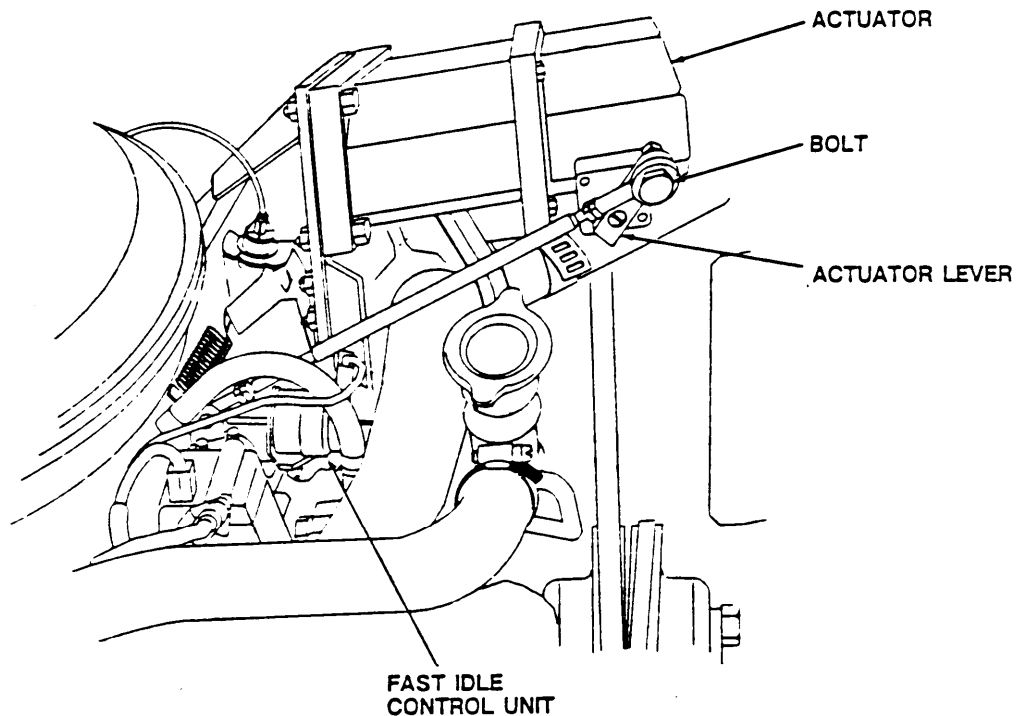

131. Position speed control actuator and controller assembly on (item 27, C5110652-1) mounting bracket. Mate actuator linkage to linkage on throttle. Install four nuts (item 36, MS51971-1), bolts (item 74, MS35307-312) flat washers (item 45, AN960C416) and lock washers (item 47, NAS1640-416) securing controller assembly to (item 27, C5110652-1) mounting bracket. Using 3/8" drive ratchet handle, 7/16" socket, and 7/16" combination wrench, tighten nuts (item 36, MS51971-1).
132. Attach linkage to actuator lever with bolt (item 85, MS35309) lock washer, (item 47, NAS1640-416) and nut (item 43, MS51971-1). Loosen locking nut, and thread the large portion of the linkage in or out until the accelerator is in the fully forward position. Idle is not affected, but the accelerator moves with the actuator arm. Tighten locking nut.

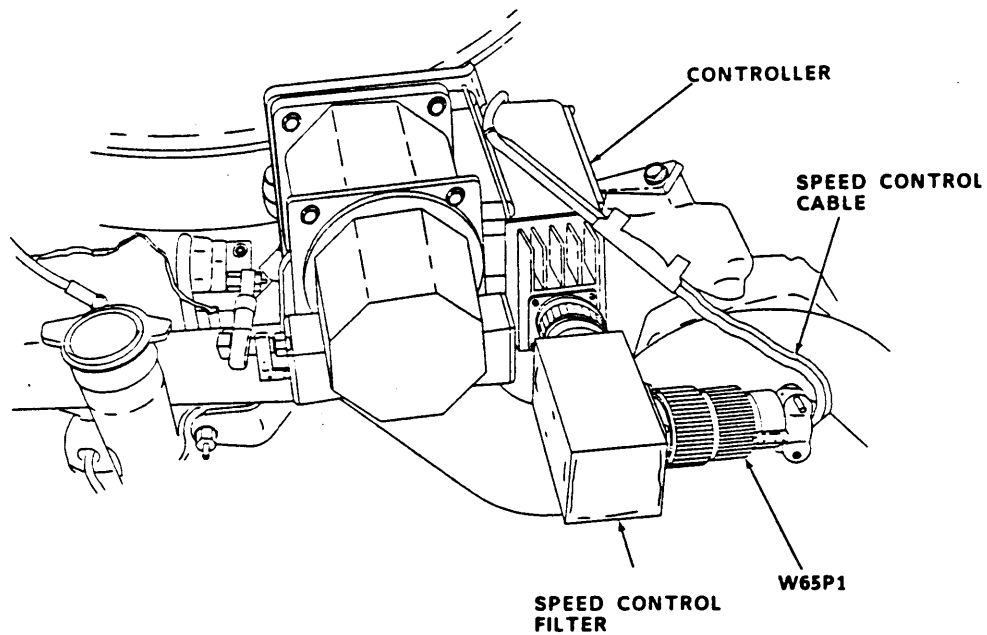

133. Install speed control filter assembly (item 53, C5131037-1) on speed control controller.
134. Connect W65P1 to front of filter assembly (item 53, C5131037-1). Using tiedown tool, secure W-65 cable (item 31, C5118955-1) with tiedowns (item 73, MS3367-2-0) leaving some slack for servicing.
135. On engine, remove cloth from intake manifold and replace air cleaner assembly.

136. Remove clamp securing transmission coolant lines to flywheel cover using 3/8" drive ratchet handle, 6" extension, and 5/8" socket.
137. Under truck, remove six bolts securing flywheel cover (GM PN 14036187) using 3/8" drive ratchet handle, 6" extension, and 15 MM socket.
138. Install new flywheel cover (item 81 C5110621-1) and secure with six bolts using 3/8" drive ratchet handle, 6" extension, and 15 MM socket.
139. Replace clamp securing transmission coolant lines to flywheel cover using 3/8" drive ratchet handle, 6" extension, and 5/8" socket.

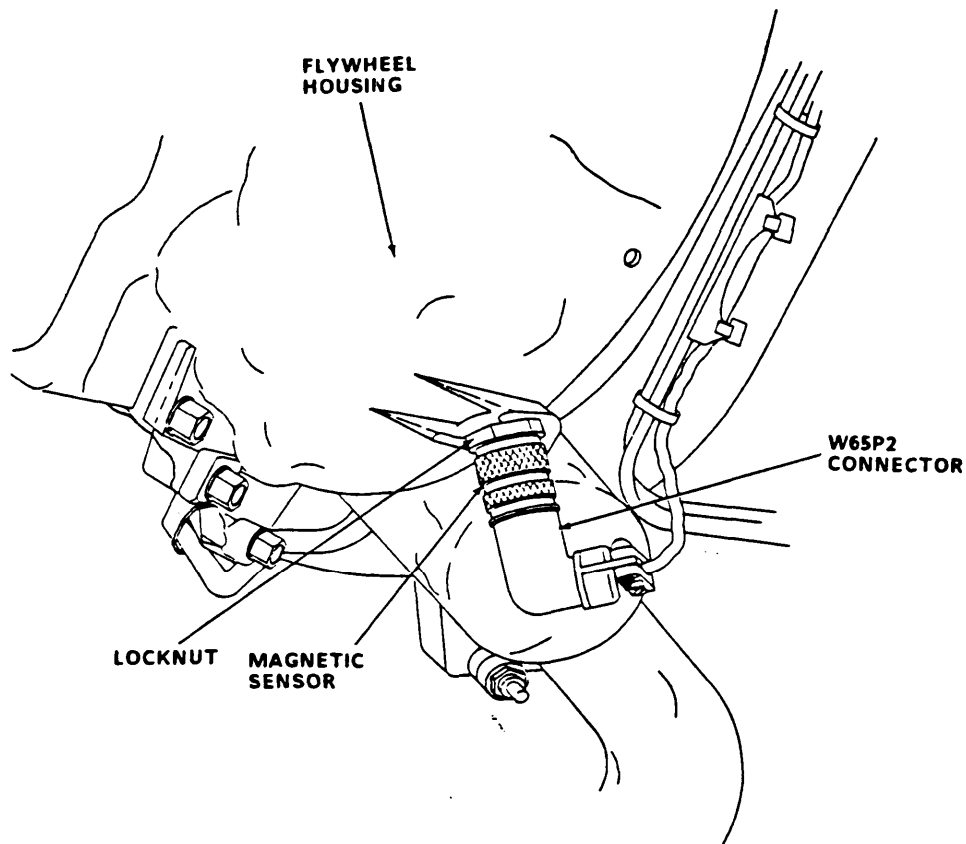

140. On magnetic sensor, position lock nut one inch from outer end of threads.
141. Insert magnetic sensor in mounting hole of flywheel. Rotate magnetic sensor to right until it contacts flywheel. Back out magnetic sensor one full turn.
142. While holding magnetic sensor, tighten lock-nut using 3/4" combination wrench.
143. Connect W65P2 to magnetic sensor connector.
144. Using tiedown (item 73, MS3367-2-0) secure W-65 cable.

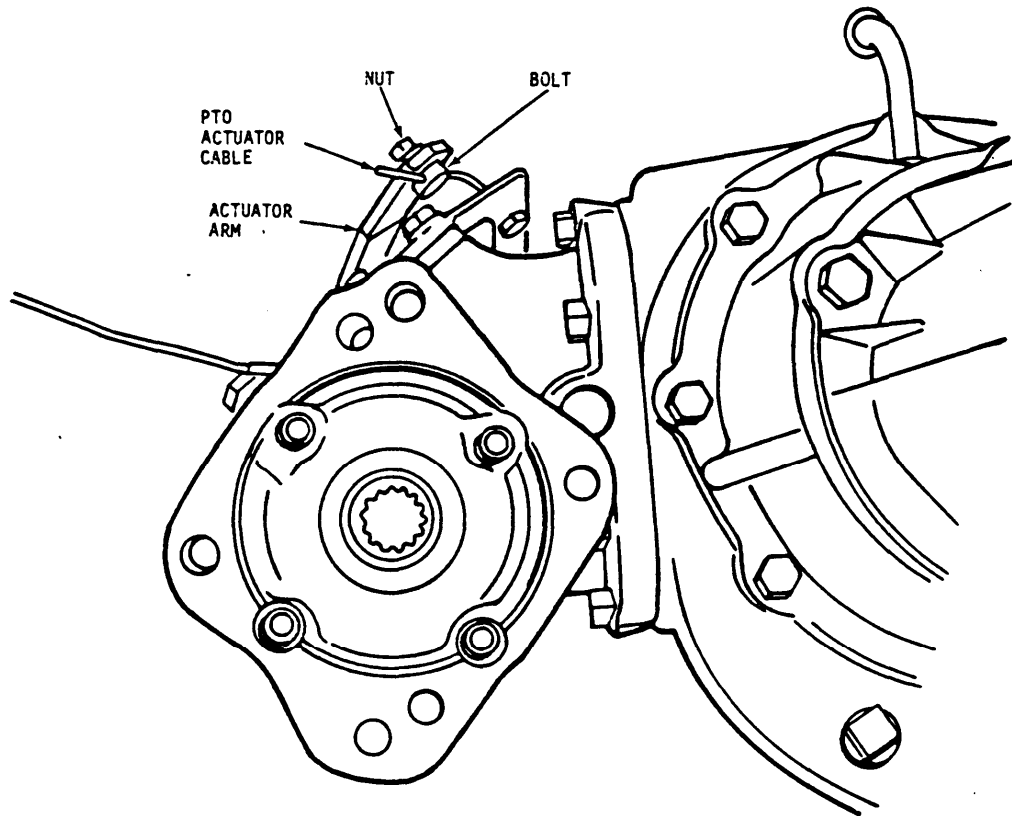

145. On tandem pump assembly, remove and retain two existing bolts where bracket (item 2, C5110944-1) will attach to tandem pump assembly (C5122498-1).
146. Place C5110944-1 mounting bracket on tandem pump assembly (C5122498-1) and secure with two existing bolts and lock washers (item 48, NAS1640-616). Using 3/8" drive ratchet handle, 6" extension, and 9/16" socket, tighten bolts.
147. On transfer case, where bracket (item 1, C5110943-1) will be attached, using a ratchet handle, two 6" extensions, 3/8" drive swivel, and 9/16" socket, remove and retain three bolts.
148. Install mounting bracket (item 1, C5110943-1) on transfer case for mounting tandem pump bracket (item 2, C5110944-1). Using 3/8" drive ratchet handle, two 6" extensions, 3/8" drive swivel, and 9/16" socket, reinstall three bolts (item 38, MS90725-62), flat washers (item 46, AN960C616), and lock washers (item 48, NAS1640-616) enough to hold bracket in place.
149. Coat tandem pump splines with thread lubricant (item 84, C5131401-1), and install tandem pump (C5122498-1) on power take-off. Carefully push tandem pump forward to engage splines.
150. Secure tandem pump assembly (C5122498-1) to PTO with two bolts (item 39, MS90725-111) and lock washers (item 49, MS35338-143). Using a 3/4" combination wrench, tighten bolts.

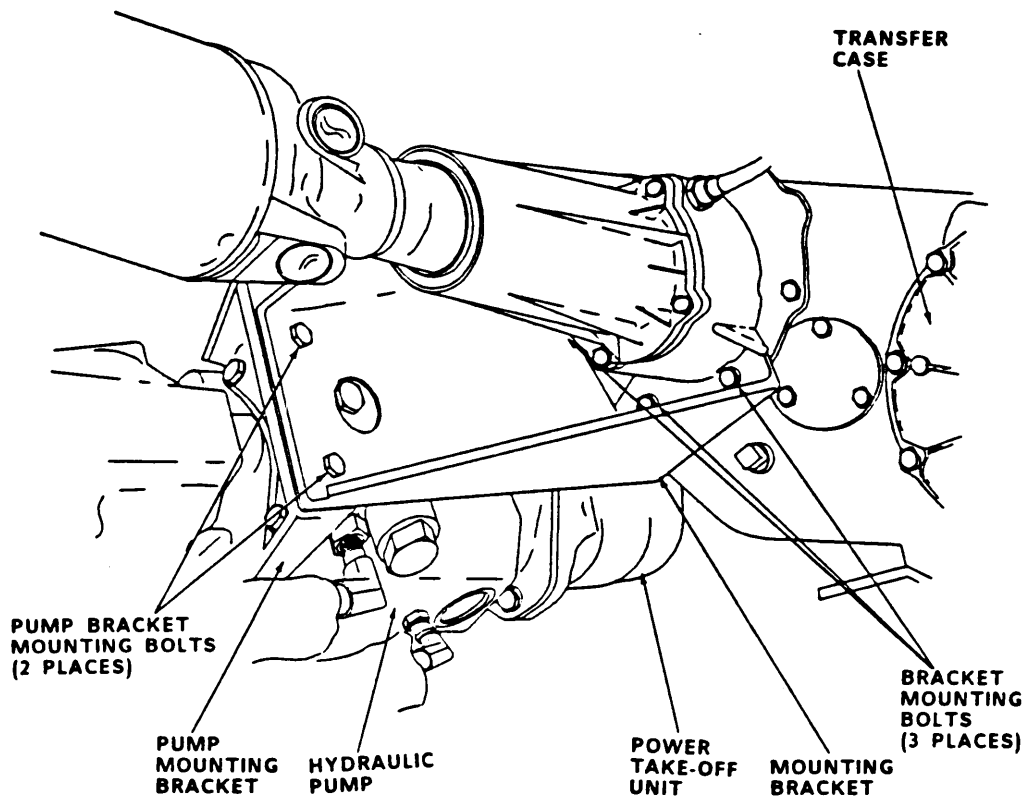

151. Using 3/8" drive ratchet handle, 6" extension, and 9/16" socket, tighten three bolts (item 38, MS90725-62) securing mounting bracket (item 1, C5110943-1) to transfer case.
152. Secure tandem pump mounting bracket (item 2, C5110944-1) to mounting bracket (item 1, C5110943-1) on transfer case with two bolts (item 38, MS90725-62), flat washers (item 46, AN960C616), lock washers (item 48, NAS1640-616), and two nuts (item 44, MS51971-3). Using a ratchet handle, 9/16" socket, and 9/16" combination wrench tighten bolts.

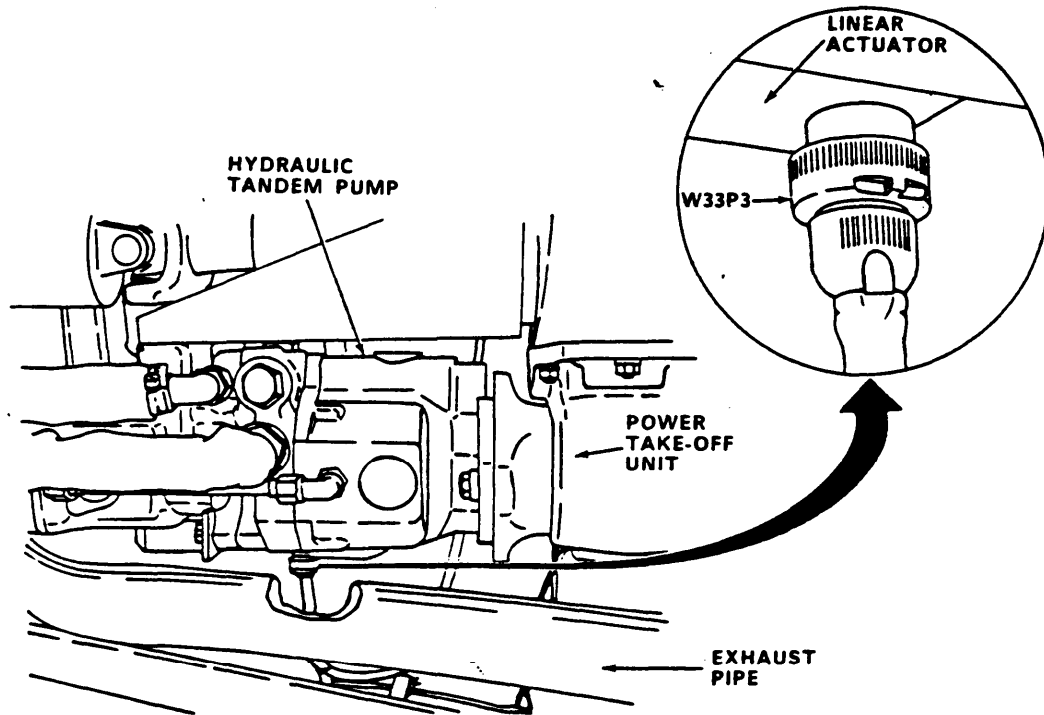

153. Connect W33P3 to tandem pump linear actuator connector.
154. Connect ground lug terminal W33E1 to frame of vehicle.

NOTE

Refer to figure 5 for installation of hydraulic lines. Observe line tags for proper installation to connect hydraulic hoses in following steps.

155. Secure generator pump low pressure return flex hose (item 100, C5122512-2) to elbow on tandem pump (C5122498-1) using 1 1/4" combination wrench. Hold elbow on pump using 12" adjustable wrench.
156. Secure tandem pump case drain flex hose (item 98, C5122511-1) to elbow on tandem pump (C5122498-1) using 7/8" combination wrench. Hold elbow on pump using 12" adjustable wrench.
157. Secure A/C sense flex hose (item 95, C5122508-1) to elbow on tandem pump (C5122498-1) using 9/16" combination wrench. Hold elbow on pump using 12" adjustable wrench.

158. Secure A/C pump high pressure flex hose (item 96, C5122509-1) to union on tandem pump (C5122498-1) using 1" combination wrench. Hold union on pump using 12" adjustable wrench.
159. Secure generator pump high pressure flex hose (item 99, C5122512-1) to tandem pump (C5122498-1) using 1-1/4" combination wrench. Hold elbow on pump using 12" adjustable wrench.

NOTE

Before drilling holes in truck bed, cover ends of flex hoses attached to tandem pump assembly with a cloth. Remove cloth when all holes have been drilled in truck bed.

160. In truck bed, mark location of four holes in accordance with Figure 4 using center punch. Using electric drill with 1/8" drill bit, drill four pilot holes in truck bed. Enlarge pilot holes with .332" drill bit.
161. Using riv-nut installation tool, install four riv-nuts (MS27130S31) in front wall of truck bed.
162. Mark location of four holes to cut in truck bed floor in accordance with Figure 4. Using electric drill with 1/8" drill bit, drill pilot holes. Enlarge holes with 1-1/2" hole saw.
163. Using saber saw, cut between 1-1/2" holes from curbside to roadside. Clean burrs in hole using file.
164. Drill six pilot holes in truck bed using 1/8" drill bit in accordance with Figure 4. Enlarge pilot holes with .332" drill bit. Install six riv-nuts in holes using riv-nut installation tool.
165. Drill four pilot holes in forward tiedown crossmember using 1/8" drill bit. Enlarge pilot holes with .201" drill bit. Tap holes with .250-20UNC-2B thread.
166. Install two channel brackets (item 7, C5110649-1 and item 8, C5110649-2) on forward tiedown crossmember using four 7/16" bolts (item 36, MS90725-6), and lock washers (item 47, NAS1640-416). Tighten bolts with 7/16" combination wrench.
167. Slide clamps (item 9, C5110650-1, item 11, C5110650-3, item 12, C5110650-4) on channel bracket (item 8, C5110649-2). Position clamps equally along bracket (item 8, C5110649-2).
168. Slide clamp (item 10, C5110650-2) on channel bracket (item 7, C5110649-1).
169. Under truck bed, drill two pilot holes in front crossmember using 1/8" drill bit in accordance with Figure 4. Enlarge pilot holes with .332" drill bit.
170. Install riv-nuts (item 94, MS27130S31) in front crossmember using riv-nut installation tool.
171. Secure channel bracket (item 6, C5110651-1) on crossmember with two bolts (item 37, MS90725-8) flat washers, (item 45, AN960C416) and lock washers (item 47, NAS1640-416). Tighten bolts using 7/16" combination wrench.
172. Using putty knife, apply thermal joint compound (item 86, C5131401-1) to wall side of hydraulic reservoir (C5122481-1).

HYDRAULIC RESERVOIR ASSEMBLY (cont.)

173. Install hydraulic reservoir and secure with four bolts (item 37, MS90725-8), lock washers (item 47, NAS1640-416), and flat washers (item 45, AN960C416) using 3/8" drive ratchet handle, 6" extension, and 7/16" socket.
174. Install clearance plate (item 13, C5122612-1) over the 1-1/2" slots cut into bed. The lines will be routed through this plate. It is not necessary to secure the plate at this time.

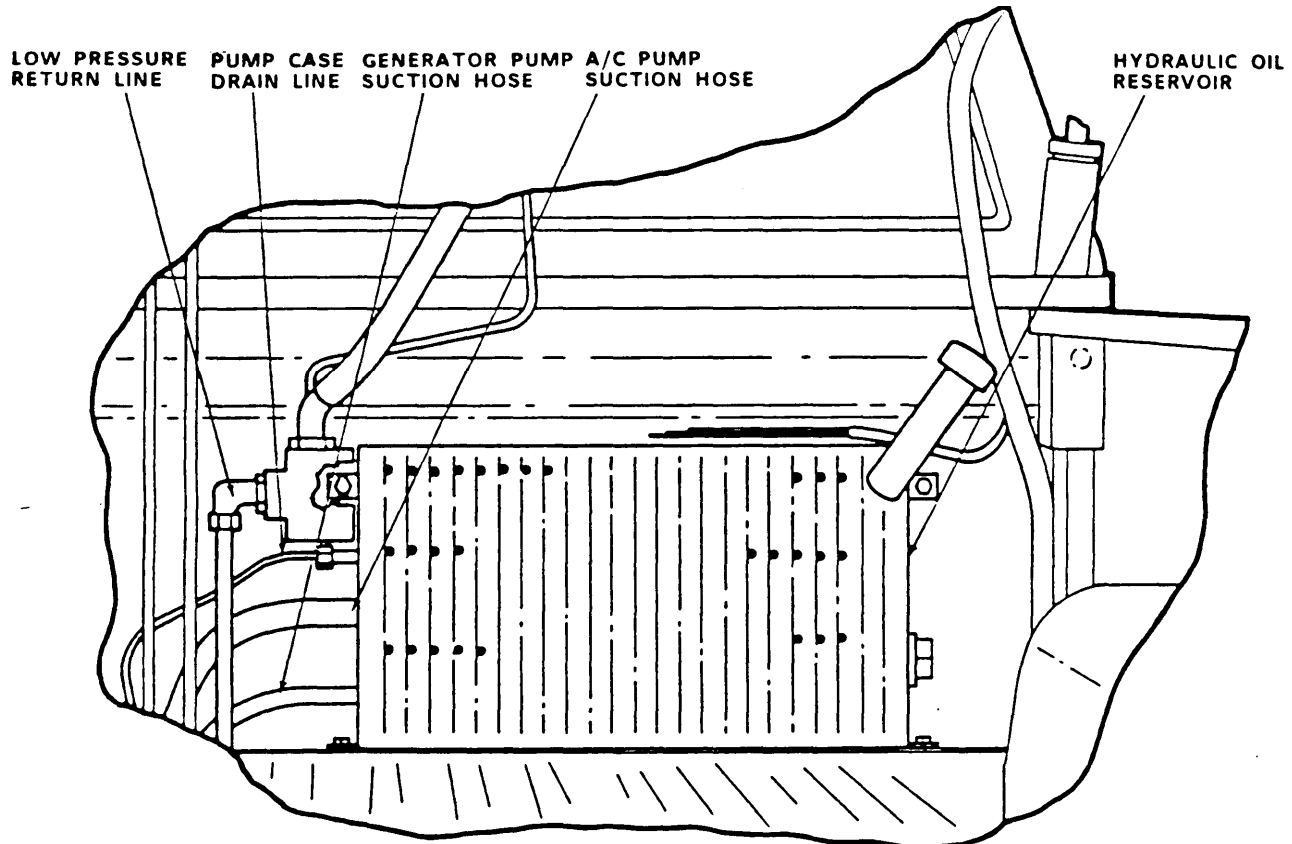

175. Install generator pump suction hose to union on reservoir (C5122481-1) and feed through the clearance plate in bed of truck. Using 1/4" flat tip screwdriver, tighten clamp (item 59, AN737TW30) on generator pump suction hose (M6000D00307).
176. Connect A/C pump suction hose (M6000H00304) to union on reservoir (C5122481-1), and feed through the clearance plate in bed of truck. Using 1/4" flat tip screwdriver, tighten clamp (item 112, AN737TW46) on A/C pump suction hose (M6000H00304).

177. Feed tandem pump case drain tube through clearance plate in bed of truck and connect to union on reservoir (C5122481-1). Using 7/8" combination wrench, tighten tandem pump case drain tube (item 106, C5111008-1) while using 12" adjustable wrench to hold union on reservoir (C5122481-1).
178. Feed generator pump low pressure return line through clearance plate in bed of truck, and connect to reservoir (C5122481-1). Using 1 1/4" combination wrench, tighten generator pump low pressure line (item 107, C5111009-1) while using 12" adjustable wrench to hold union on reservoir (C5122481-1).

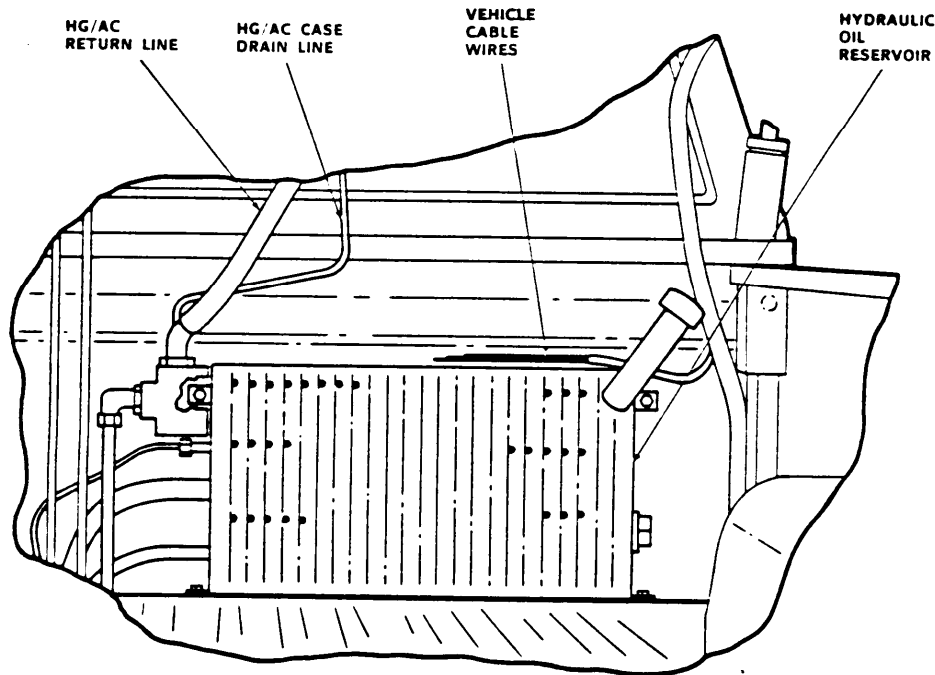

179. Connect HG/AC case drain line (item 111, C5111013-1) to reservoir (C5122481-1). Using 7/8" combination wrench, tighten HG/AC case drain line (item 111, C5111013-1) while using 12" adjustable wrench to hold elbow on reservoir (C5122481-1).
180. Connect HG/AC return line (item 97, C5122510-1) to reservoir (C5122481-1). Using 1 1/2" combination wrench, tighten HG/AC return line (item 97, C5122510-1) while using 15" adjustable wrench to hold elbow on reservoir (C5122481-1).
181. Position a 24" piece of insulation sleeving (item 92, M23053/5-108-0) over W-33 cable where wire connections are to be made to reservoir. Connect three wires of W-33 cable (item 29, C5110787-1) to hydraulic reservoir (C5122481-1). Observe tags for proper installation (blue to white, red to red, and yellow to green). Crimp splice fasteners (item 89, M7928/5-4) using crimping pliers.

NOTE

Refer to figure 5 for hydraulic line installation. Observe line tags for proper installation while connecting hydraulic lines.

182. In truck bed, place sense, A/C high pressure, and generator high pressure hydraulic lines through holes in truck bed floor. Secure hydraulic lines in clamps on forward tiedown crossmember in accordance with figure 4.
183. Install second plate (item 14, C5122613-1) in truck bed and secure with six bolts (item 37, MS90725-8), flat (item 45, AN960C416) and lock washers (item 47, NAS1640-416). Using 7/16" combination wrench, tighten bolts.
184. Under truck bed, secure hydraulic lines in clamps on forward crossmember in accordance with figure 4.

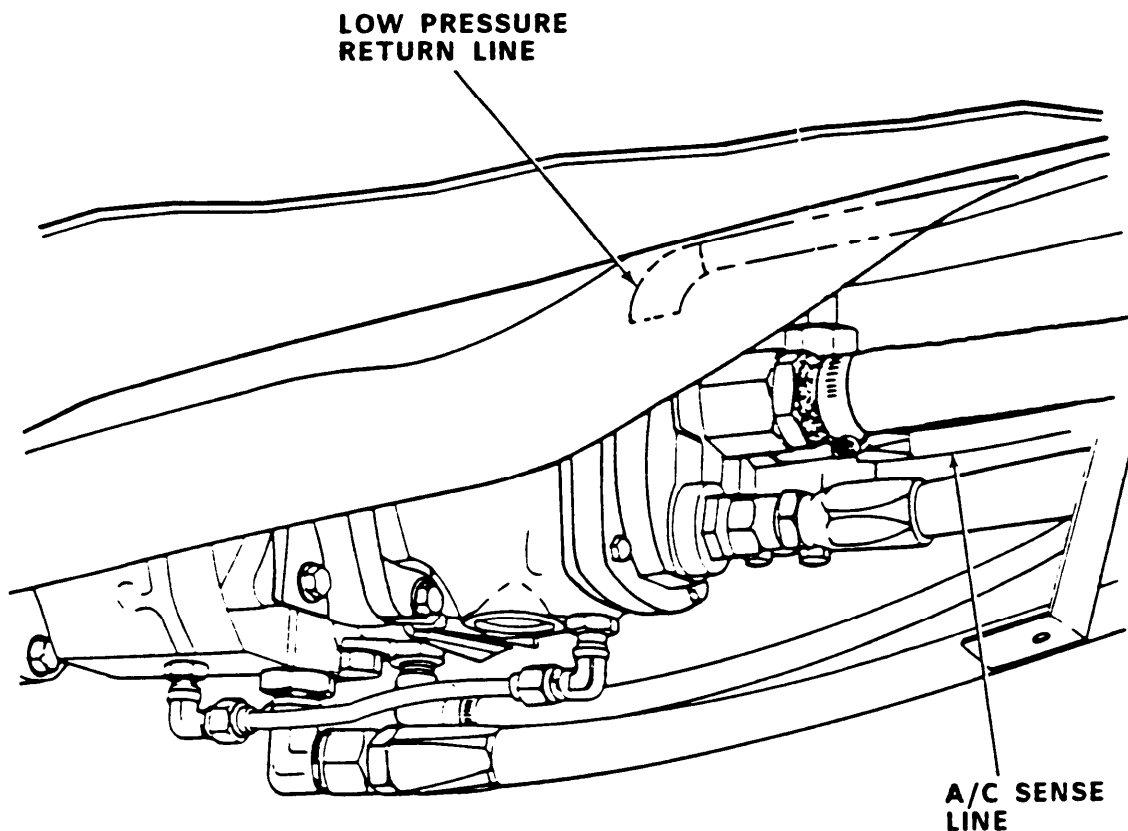

185. Position protective sleeve (item 56, C5131118-3) over generator pump low pressure return line (item 107, C5111009-1). Slide sleeve up hose, until top of sleeve is positioned just below channel bracket (item 6, C5110651-1). Trim sleeve as necessary. Using 1/4" flat tip screwdriver, tighten hose clamp (item 60, AN737TW58) securing protective sleeve (item 56, C5131118-3).

186. Tighten union (item 113, AN815-12D) on generator pump low pressure return flex hose (item 100, C5122512-2) using 12" adjustable wrench and 1-1/4" combination wrench.
187. Connect generator pump low pressure return line (item 107, C5111009-1) on union (item 113, AN815-12D) and tighten using 1-1/4" combination wrench. Hold union (item 113, AN815-12D) connected to generator pump low pressure return hose (item 100, C5122512-2) using 12" adjustable wrench.
188. Position protective sleeve (item 55, C5131118-2) over tandem pump case drain line (item 106, C5111008-1). Slide sleeve up hose until top of sleeve is positioned just below channel bracket (item 6, C5110651-1). Trim sleeve as necessary. Using 1/4" flat tip screwdriver, tighten hose clamp (item 59, AN737TW30) securing protective sleeve (item 55, C5131118-2).
189. Connect union (item 115, AN815-8D) to tandem pump case drain flex hose (item 98, C5122511-1) and tighten using 12" adjustable wrench while holding flex hose (item 98, C5122511-1) using 7/8" combination wrench.
190. Connect tandem pump case drain line (item 106, C5111008-1) onto union (item 115, AN815-8D) and tighten using 7/8" combination wrench. Hold union (item 115, AN815-8D) connected to tandem pump case drain flex hose (item 98, C5122511-1) using 12" adjustable wrench.
191. Position protective sleeve (item 54, C5131118-1) over A/C pump sense line (item 110, C5111012-1). Slide sleeve up hose until top of sleeve is positioned just below channel bracket (item 6, C5110651-1). Trim sleeve as necessary. Using 1/4" flat tip screwdriver, tighten hose clamp (item 58, AN737TW22) securing protective sleeve (item 54, C5131118-1).
192. Connect union (item 114, AN815-4D) to A/C pump sense flex hose (item 95, C5122508-1) and tighten using 12" adjustable wrench while holding flex hose (item 95, C5122508-1) using 9/16" combination wrench.
193. Connect A/C pump sense line (item 110, C5111012-1) onto union (item 114, AN815-4D) and tighten using 9/16" combination wrench. Hold union (item 114, AN815-4D) connected to A/C pump sense flex hose (item 95, C5122508-1) using 12" adjustable wrench.
194. Position protective sleeve (item 55, C5131118-2) over A/C pump high pressure line (item 109, C5111011-1). Slide sleeve up hose until top of sleeve is positioned just below channel bracket (item 6, C5110651-1). Trim sleeve as necessary. Using 1/4" flat tip screwdriver, tighten hose clamp (item 59, AN737TW30) securing protective sleeve (item 55, C5131118-2).
195. Connect A/C pump high pressure line (item 109, C5111011-1) onto flex hose (item 96, C5122509-1) and tighten using 1" combination wrench while holding A/C pump high pressure flex hose (item 96, C5122509-1) using 12" adjustable wrench.
196. Connect union (item 113, AN815-12D) to generator pump high pressure flex hose (item 99, C5122512-1) and tighten using 12" adjustable wrench while holding flex hose (item 99, C5122512-1) using 1-1/4" combination wrench.

197. Position protective sleeve (item 56, C5131118-3) over generator pump high pressure line (item 108, C5111010-1). Slide sleeve up hose until top of sleeve is positioned just below channel bracket (item 6, C5110651-1). Trim sleeve as necessary. Using 1/4" flat tip screwdriver, tighten hose clamp (item 60, AN737TW58) securing protective sleeve (item 56, C5131118-3).
198. Connect generator pump high pressure line (item 108, C5111010-1) onto union (item 113, AN815-12D) and tighten using 1-1/4" combination wrench while holding union (item 113, AN815-12D) connected to generator pump high pressure flex hose (item 99, C5122512-1) using 12" adjustable wrench.
199. Position protective sleeve (item 55, C5131118-2) over A/C pump suction hose (M6000H00304). Slide sleeve up hose until top of sleeve is positioned just below channel bracket (item 6, C5110651-1). Trim sleeve as necessary. Using 1/4" flat tip screwdriver, tighten hose clamp (item 59, AN737TW30) securing protective sleeve (item 55, C5131118-2).
200. Slide hose clamp (item 112, AN737TW46) onto A/C pump suction hose (M6000H00304). Push hose onto union of tandem pump (C5122498-1). Using 1/4" flat tip screwdriver, tighten hose clamp (item 112, AN737TW46).
201. Position protective sleeve (item 55, C5131118-2) over generator pump suction hose (M6000D00307). Slide sleeve up hose until top of sleeve is positioned just below channel bracket (item 6, C5110651-1). Trim sleeve as necessary. Using 1/4" flat tip screwdriver, tighten hose clamp (item 59, AN737TW30) securing protective sleeve (item 70, C5131118-2).
202. Slide hose clamp (item 59, AN737TW30) onto generator pump suction hose (M6000D00307). Push hose onto union of tandem pump (C5122498-1). Using 1/4" flat tip screwdriver, tighten hose clamp (item 59, AN737TW30).
203. In truck bed, connect union to A/C sense line (item 110, C5111012-1). Tighten union (item 114, AN815-4D) using 12" adjustable wrench while holding A/C sense line (item 110, C5111012-1) using 9/16" combination wrench.
204. Connect A/C sense flex hose (item 95, C5122508-1) onto union (item 114, AN815-4D) and tighten using 9/16" combination wrench. Hold union (item 114, AN815-4D) using 12" adjustable wrench.
205. Position protective sleeve (item 54, C5131118-1) over A/C sense line flex hose (item 95, C5122508-1). Slide sleeve down flex hose (item 95, C5122508-1). Using 9/16" combination wrench, hold A/C sense flex hose (item 95, C5122508-1). Using 12" adjustable wrench, tighten quick disconnect (item 101, C5131409-1) to flex hose (item 95, C5122508-1). Trim sleeve as necessary, and secure with tiedown strap (item 73, MS3367-2-0).

206. Using 1" combination wrench, hold A/C high pressure line (item 109, C5111011-1). Using 12" adjustable wrench, tighten A/C high pressure flex hose (item 96, C5122509-1) to A/C high pressure line (item 109, C5111011-1).
207. Position protective sleeve (item 55, C5131118-2) over A/C high pressure flex hose (item 96, C5122509-1). Slide sleeve down flex hose. Using 1" combination wrench, hold A/C high pressure line flex hose (item 96, C5122509-1). Using 12" adjustable wrench, tighten quick disconnect (item 103, C5131409-3) to flex hose (item 96, C5122509-1). Trim sleeve as necessary, and secure with tiedown strap (item 73, MS3367-2-0).
208. Using 1-1/4" combination wrench, hold generator pump high pressure line (item 108, C5111010-1). Using 12" adjustable wrench, tighten union (item 113, AN815-12D) to generator pump high pressure line (item 108, C5111010-1).
209. Using 12" adjustable wrench, hold union (item 113, AN815-12D). Using 1-1/4" combination wrench, tighten generator pump high pressure flex hose (item 99, C5122512-1) onto union (item 113, AN815-12D).
210. Position protective sleeve (item 56, C5131118-3) over generator pump high pressure flex hose (item 99, C5122512-1). Slide sleeve down flex hose (item 99, C5122512-1). Using 1-1/4" combination wrench, hold generator pump high pressure flex hose (item 99, C5122512-1). Using 12" adjustable wrench, tighten quick disconnect (item 105, C5131409-4) to generator pump high pressure flex hose (item 99, C5122512-1). Trim sleeve as necessary, and secure with tiedown strap (item 73, MS3367-2-0).
211. Using 7/8" combination wrench, hold HG/AC case drain line (item 111, C5111013-1). Using 12" adjustable wrench, tighten union (item 115, AN815-8D) to HG/AC case drain line (item 111, C5111013-1).
212. Using 12" adjustable wrench, hold union (item 115, AN815-8D). Using 7/8" combination wrench, tighten HG/AC case drain flex hose (item 98, C5122511-1) onto union (item 115, AN815-8D).
213. Position protective sleeve (item 55, C5131118-2) over HG/AC case drain flex hose (item 98, C5122511-1). Slide sleeve down flex hose (item 98, C5122511-1). Using 7/8" combination wrench, hold HG/AC case drain flex hose (item 98, C5122511-1). Using 12" adjustable wrench, tighten quick disconnect (item 102, C5131409-2) to HG/AC case drain flex hose (item 98, C5122511-1). Trim sleeve as necessary, and secure with tiedown strap (item 73, MS3367-2-0).
214. Position protective sleeve (item 56, C5131118-3) over HG/AC return (item 97, C5122510-1). Slide sleeve down HG/AC return line (item 97, C5122510-1). Using 1-1/2" combination wrench, hold HG/AC return line (item 97, C5122510-1). Using 15" adjustable wrench, tighten quick disconnect (item 104, C5131409-5) to HG/AC return line (item 97, C5122510-1). Trim sleeve as necessary, and secure with tiedown strap (item 73, MS3367-2-0).

215. Using 16 oz hammer and center punch, mark center of four holes on transmission mounting crossmember in accordance with skid plate mounting modifications on Figure 4. Using electric drill with 1/8" drill bit drill four pilot holes. Enlarge the four holes with .406" drill bit.

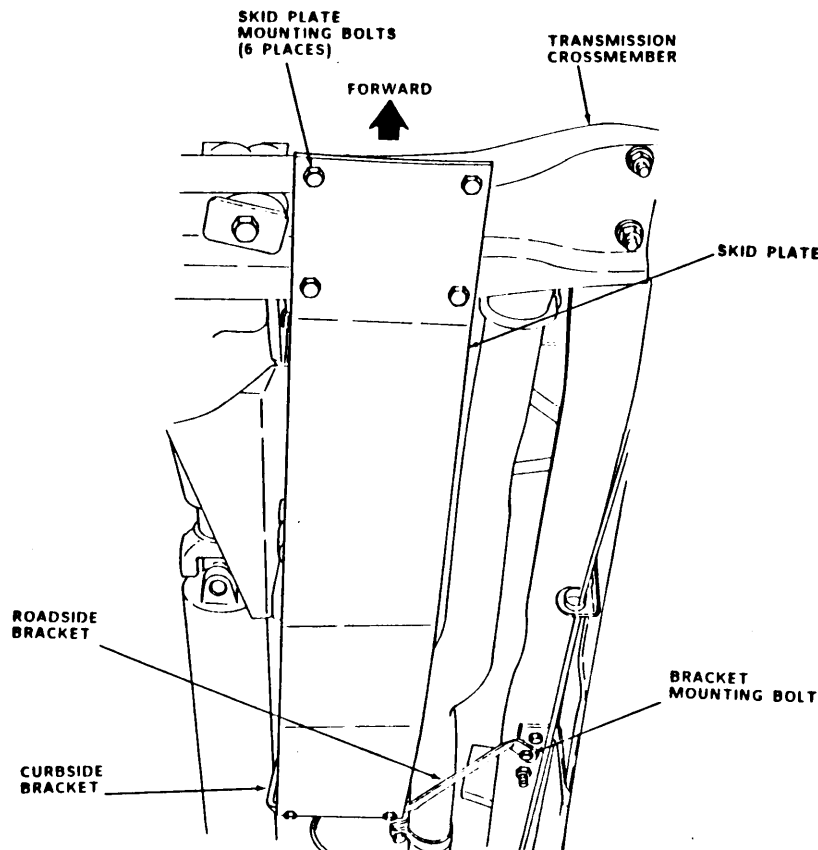

216. Install roadside skid plate bracket (item 5, C5118948-1) on left frame rail with two bolts (item 37, MS90725-8), nuts (item 43, MS51971-1), flat washers (item 45, AN960C416) and lock washers (item 47, NAS1640-416). Install bolts in available hole of frame rail. Using 3/8" drive ratchet handle, 7/16" socket, and 7/16" combination wrench, tighten bolts (item 37, MS90725-8).

NOTE

If vehicle to remodified is a 1985 M-1028A1, proceed to step 219.

217. Install curbside skid plate bracket (item 4, C5118947-1) to fuel and brake line crossmember with two bolts (item 37, MS90725-8), nuts (item 43, MS51971-1), flat washers (item 45, AN960C416) and lock washers (item 47, NAS1640-416). Use two holes available in bottom of crossmember. Using 3/8" drive ratchet handle, 7/16" socket, and 7/16" combination wrench, tighten bolts (item 37, MS90725-8). Proceed to step 220.

218. Using 3/8" drive ratchet handle, and 7/16" socket, secure spacer plate (C5132683-1) onto curbside skid plate bracket (item 4, C5118947-1) with two bolts (MS35200-74), flat washers (item 45, AN960C416), lock washers (item 47, NAS1640-416), and nuts (item 43, MS51971-1).
219. Secure spacer plate (C5132683-1) and skid plate bracket (item 4, C5118947-1) to fuel and brakeline crossmember using two available holes. Using 3/8" drive ratchet handle, and 1/2" socket, tighten two bolts (MS35307-338), flat washers (AN960C516), lock washers (item 63, NAS1640-516), and nuts (item 64, MS51971-2).
220. Position skid plate (item 3, C5118946-1) under tandem pump assembly (C5122498-1). Secure skid plate (item 3, C5118946-1) with six bolts (item 38, MS90725-62), nuts (item 44, MS51971-3), flat (item 46, AN960C616) and lock washers (item 48, NAS1640-616). Using 3/8" drive ratchet handle, 9/16" socket, and 9/16" combination wrench, tighten bolts (item 38, MS90725-62).
221. Fill hydraulic reservoir with approximately 8 gallons of Mil-F-17111. Recheck fluid level after running the hydraulic system.

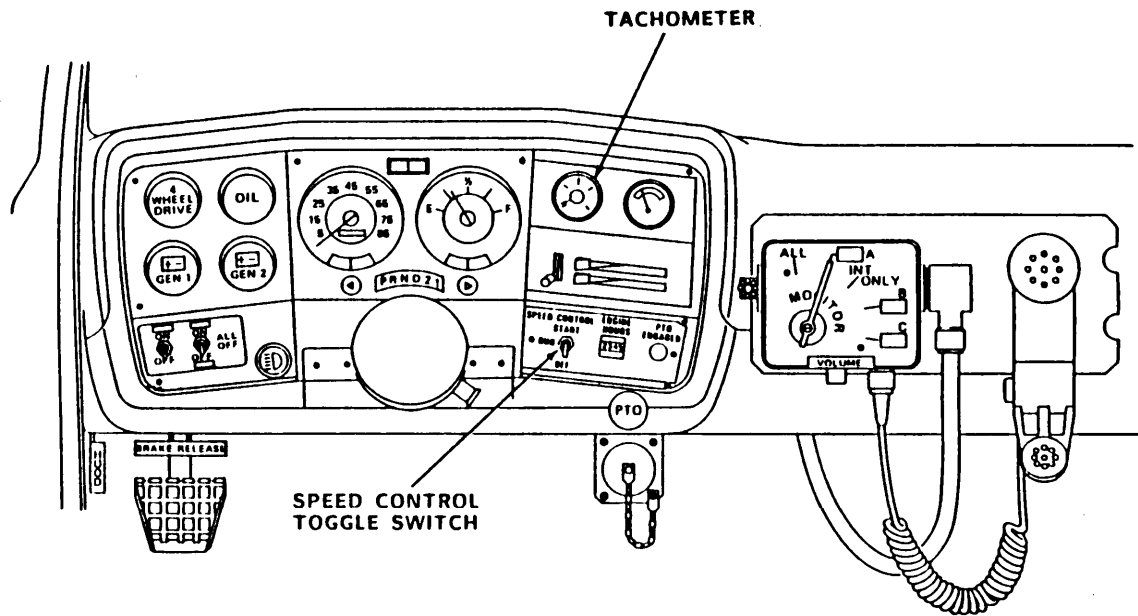

1. Ensure that all electrical connections are tight, and that all hardware attachments are secure.
2. Place cable on front battery negative (-) terminal, tighten nut, and place protective cover over terminal.
3. Place cable on rear battery negative (-) terminal, tighten nut, and place protective cover over terminal.
4. Place gear shift lever in PARK (P) and set EMERGENCY BRAKE.
5. Start vehicle engine and allow to idle.
6. Move speed control toggle switch to RUN.
7. Move speed control toggle switch to START and hold. Engine speed should not increase.
8. Move speed control toggle switch to OFF.

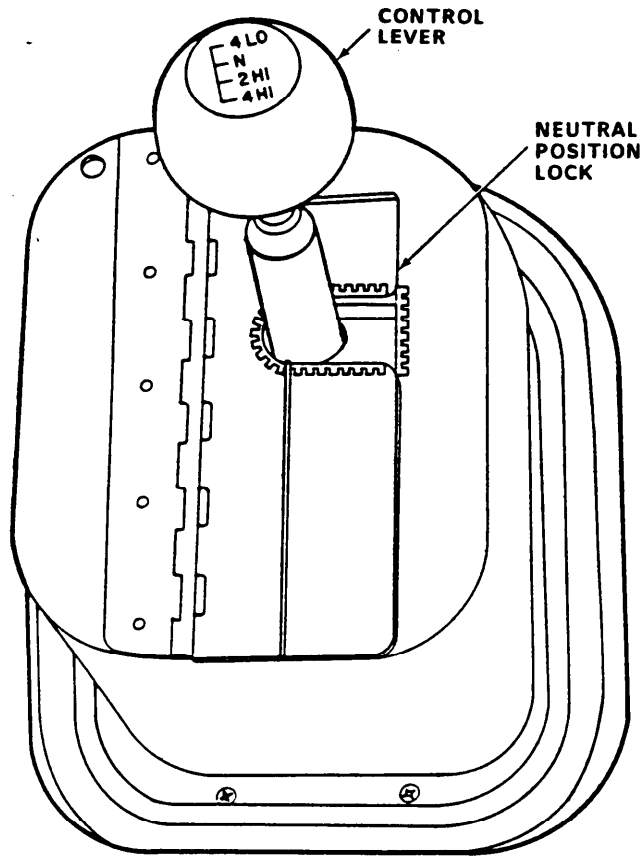

9. Set transfer case control lever to NEUTRAL (N) and engage transfer case lockout.

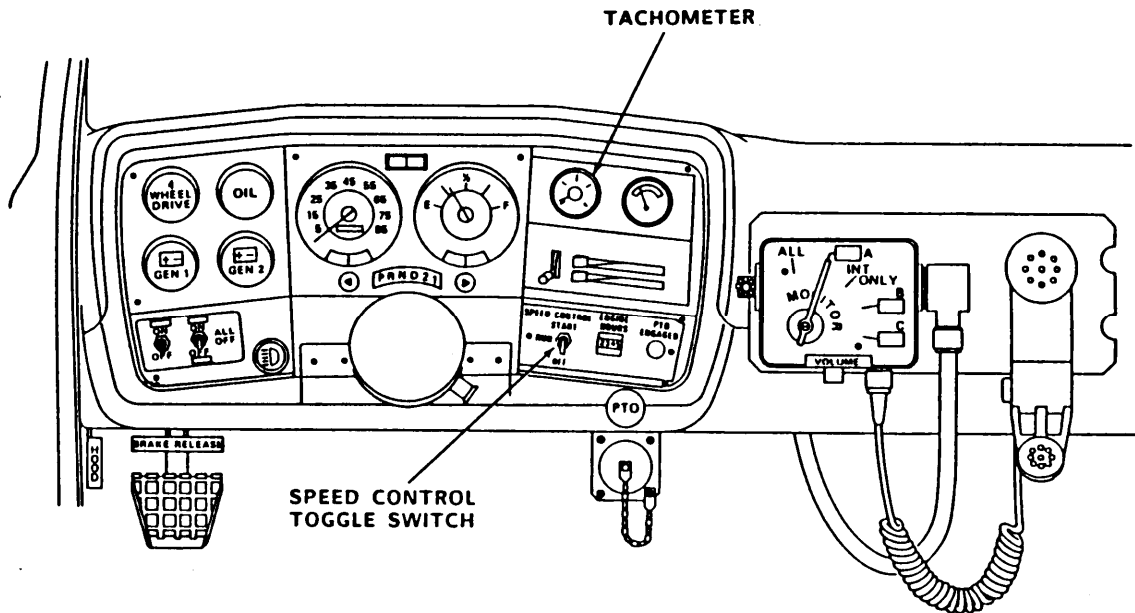

10. Move speed control toggle switch to RUN.
11. Move speed control toggle switch to START and hold. Engine speed should increase to 2000 RPM.
12. If engine speed does not increase from idle, check for defective transfer case lockout switch.
13. If 2000 RPM is not obtained, but engine speed increases above 1400 RPM, release speed control toggle switch to RUN.
14. Using NO. 2 cross tip screwdriver, remove and retain two screws securing RPM regulator assembly (item 32, C5122557-1) to instrument panel. Pull RPM regulator assembly out and position to allow access to "R1" control.

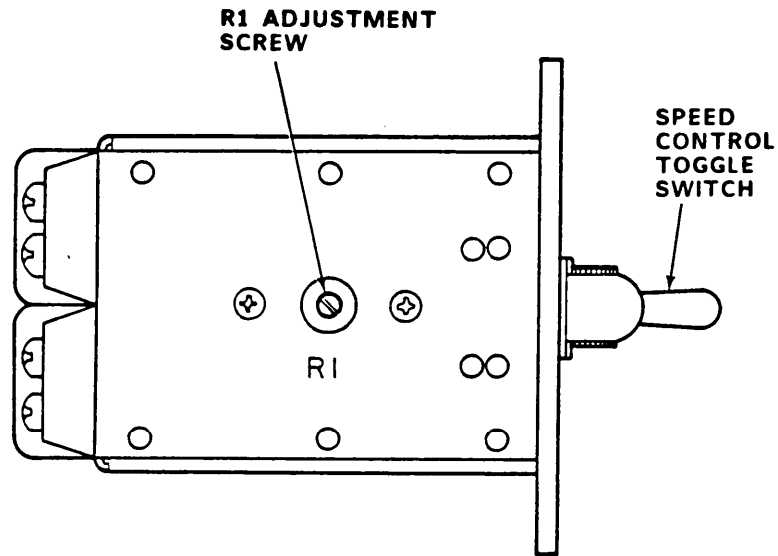

15. Using 1/8" flat tip screwdriver, adjust "R1" control on RPM regulator assembly (item 32, C5122557-1) for a 2000 RPM reading when holding speed control toggle switch in START position.
16. Release speed control toggle switch to RUN. Engine speed should decrease to 1400 RPM +/- 10 RPM.

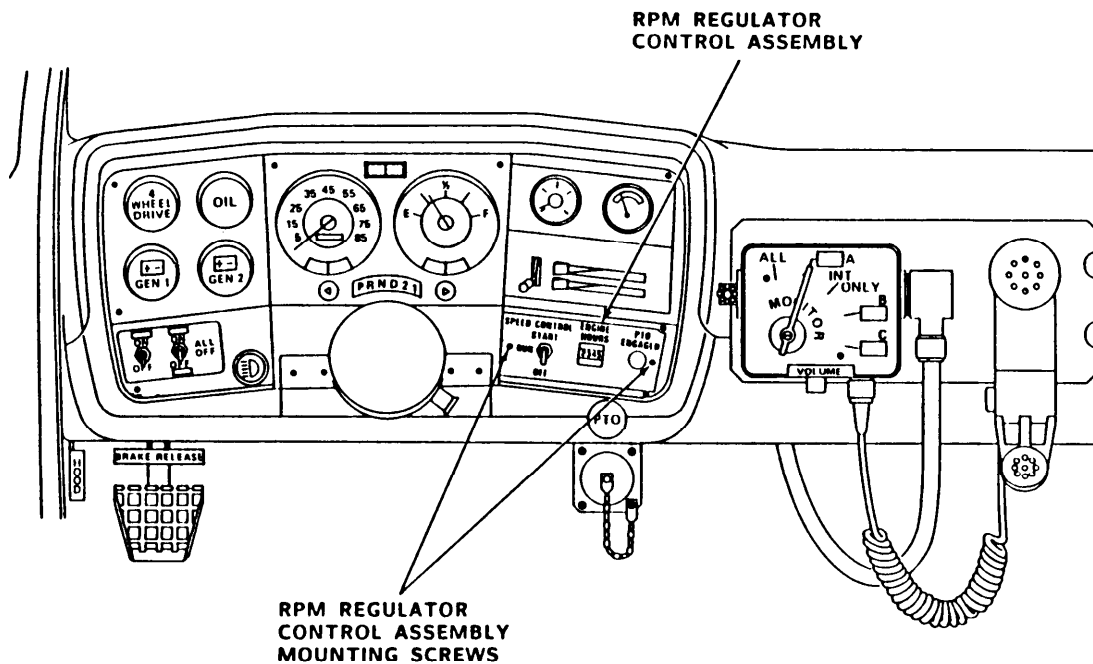

17. Reinstall RPM regulator assembly (item 32, C5122557-1) and secure with two screws (item 50, MS51959-70B). Using a NO.2 cross tip screwdriver, tighten screws.

WARNING

If transfer case is not in NEUTRAL, vehicle will attempt to move forward when gear shift lever is set to DRIVE. Repeat setting transfer case control lever to NEUTRAL.

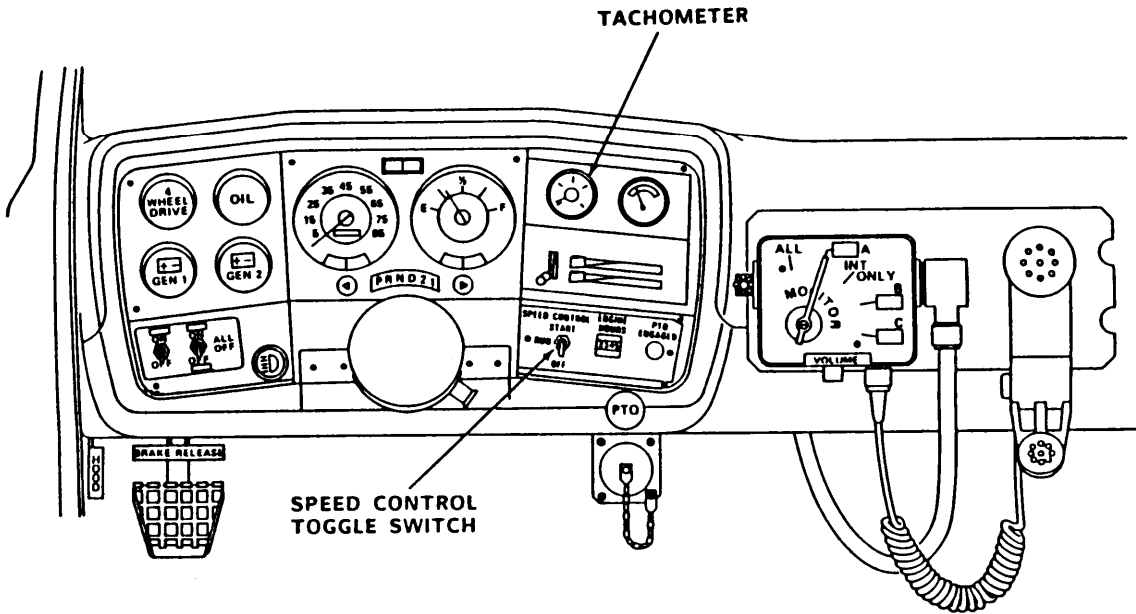

18. Set transmission gear shift lever to DRIVE (D).
19. Move speed control toggle switch to RUN.
20. Move speed control toggle switch to START and hold for about two seconds to assure that transmission has shifted to third gear. Engine speed should increase to 2000 RPM.
21. Release speed control toggle switch to RUN. Engine speed should drop to 1400 RPM.
22. Move speed control toggle switch to OFF.

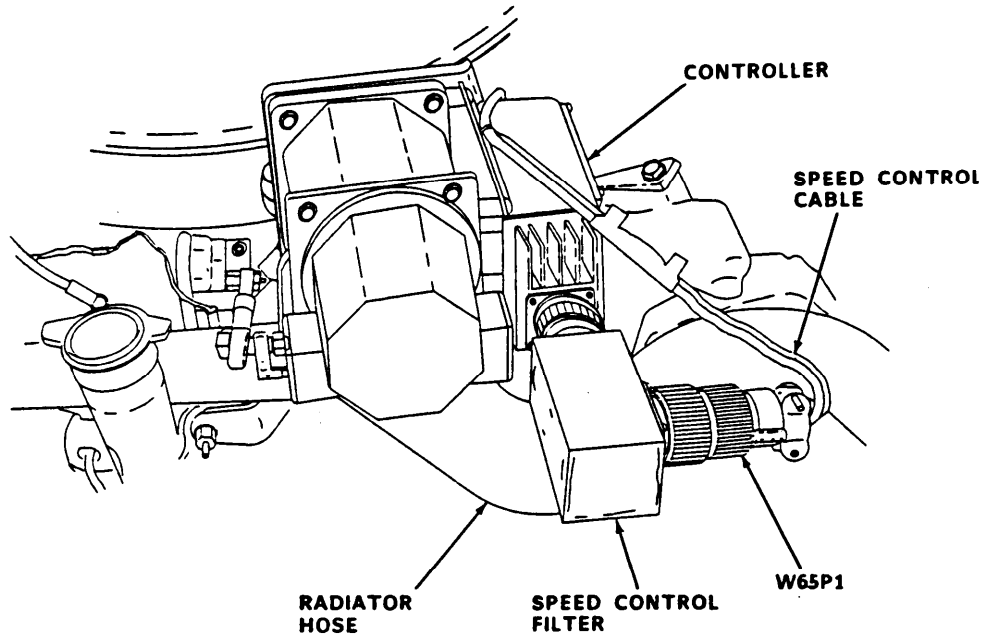

23. With engine running at operating temperature, check for contact between upper radiator hose and W-65 cable. If no contact is made, turn vehicle engine off, then place gear shift lever to PARK, and transfer case lever to 2H.
24. If contact is made, between radiator hose and W-65 cable, turn engine off and allow engine to cool. Using a 1/4" flat tip screwdriver, loosen screw securing hose clamp at upper end of radiator hose. Twist radiator hose 1/4 turn clockwise. Using same tool tighten screw securing hose clamp.

By Order of the Secretary of the Army:

CARL E. VUONO
General, United States Army
Chief of Staff

Official:

WILLIAM J. MEEHAN, II
Brigadier General, United States Army
The Adjutant General

DISTRIBUTION:

To be distributed in accordance with DA Form 12-36, Unit, Direct Support and General Support and General Support Maintenance requirements for AN/TRQ-30(V); AN/TRQ-30(V) 1-2; AN/TRQ-30(V)4.

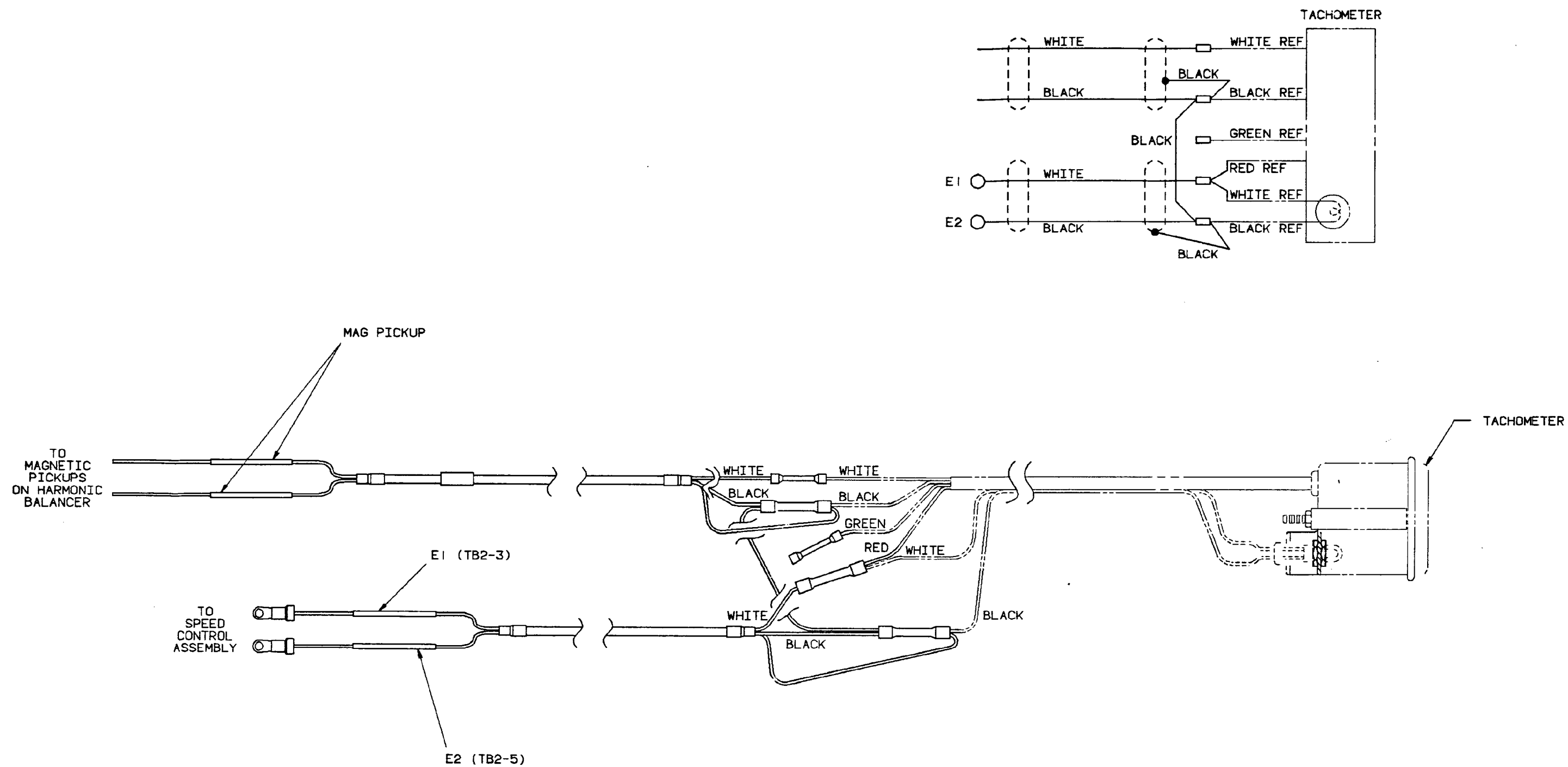

FIGURE 1.
W-67 CABLE ASSEMBLY
FP-1/(FP-2 blank)

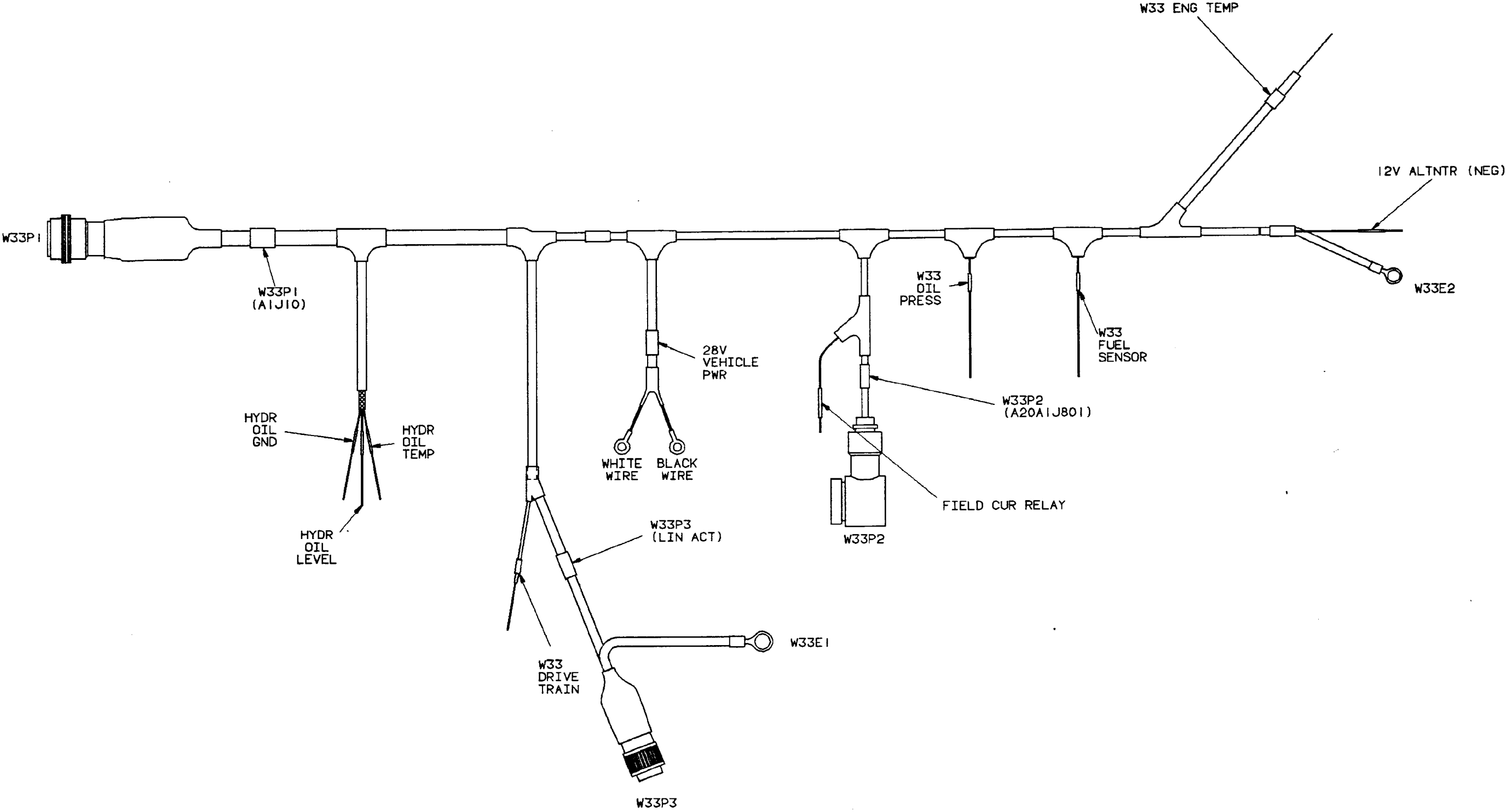

FIGURE 2.
W-33 CABLE ASSEMBLY
FP-3/(FP-4 blank)

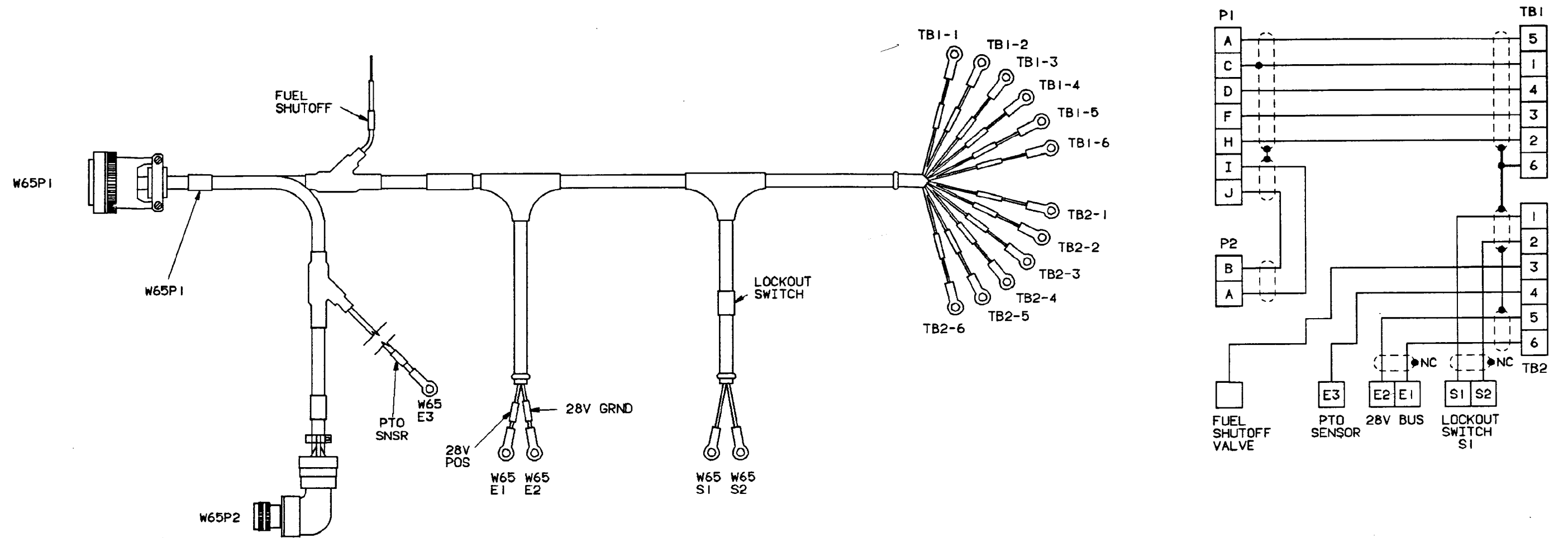

FIGURE 3.
W-65 CABLE ASSEMBLY
FP-5,(FP-6 blank)

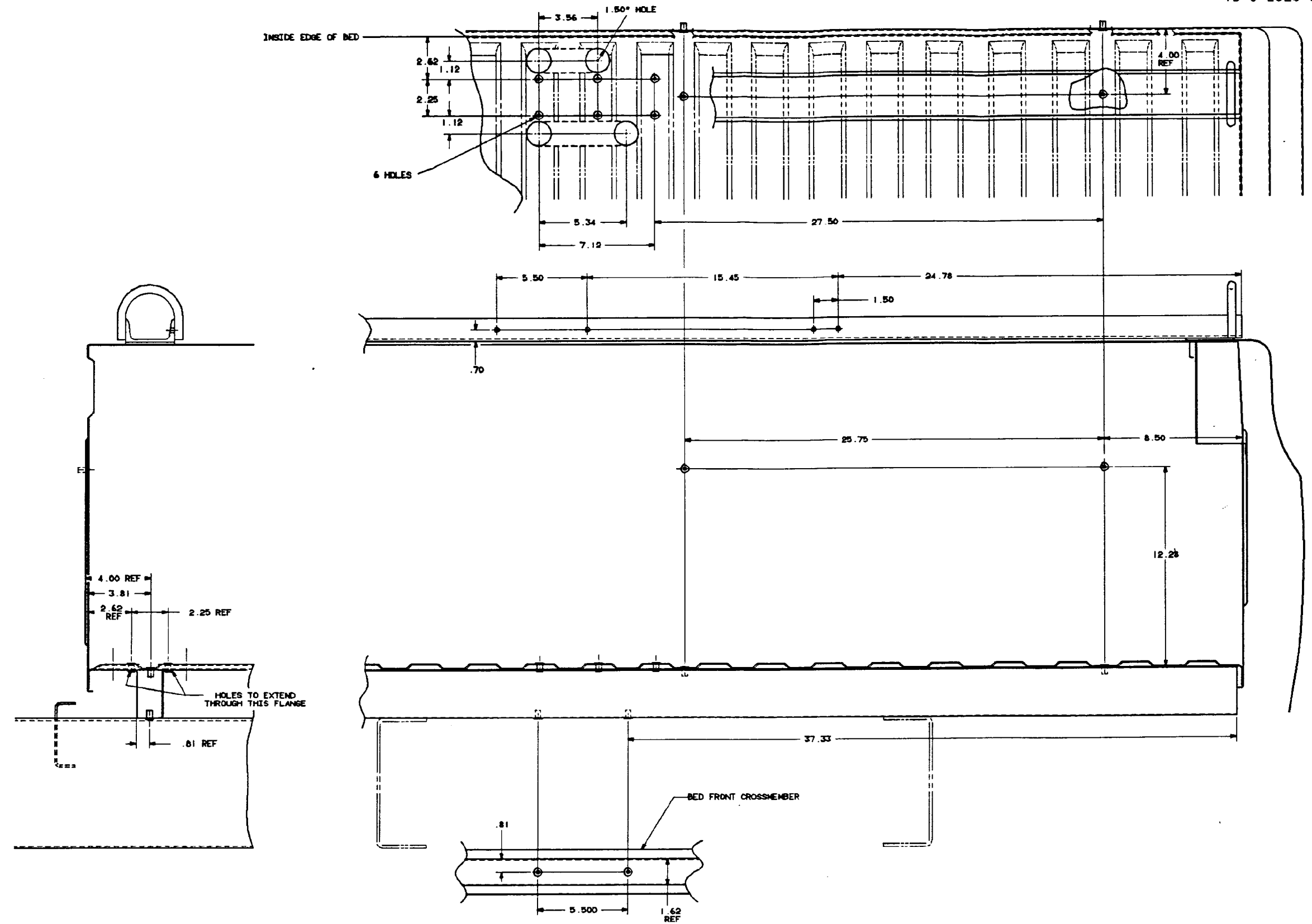

FIGURE 4.
TRUCK BED MODIFICATION DRAWING
(SHEET 1 OF 2)
FP-7/(FP-8 blank)

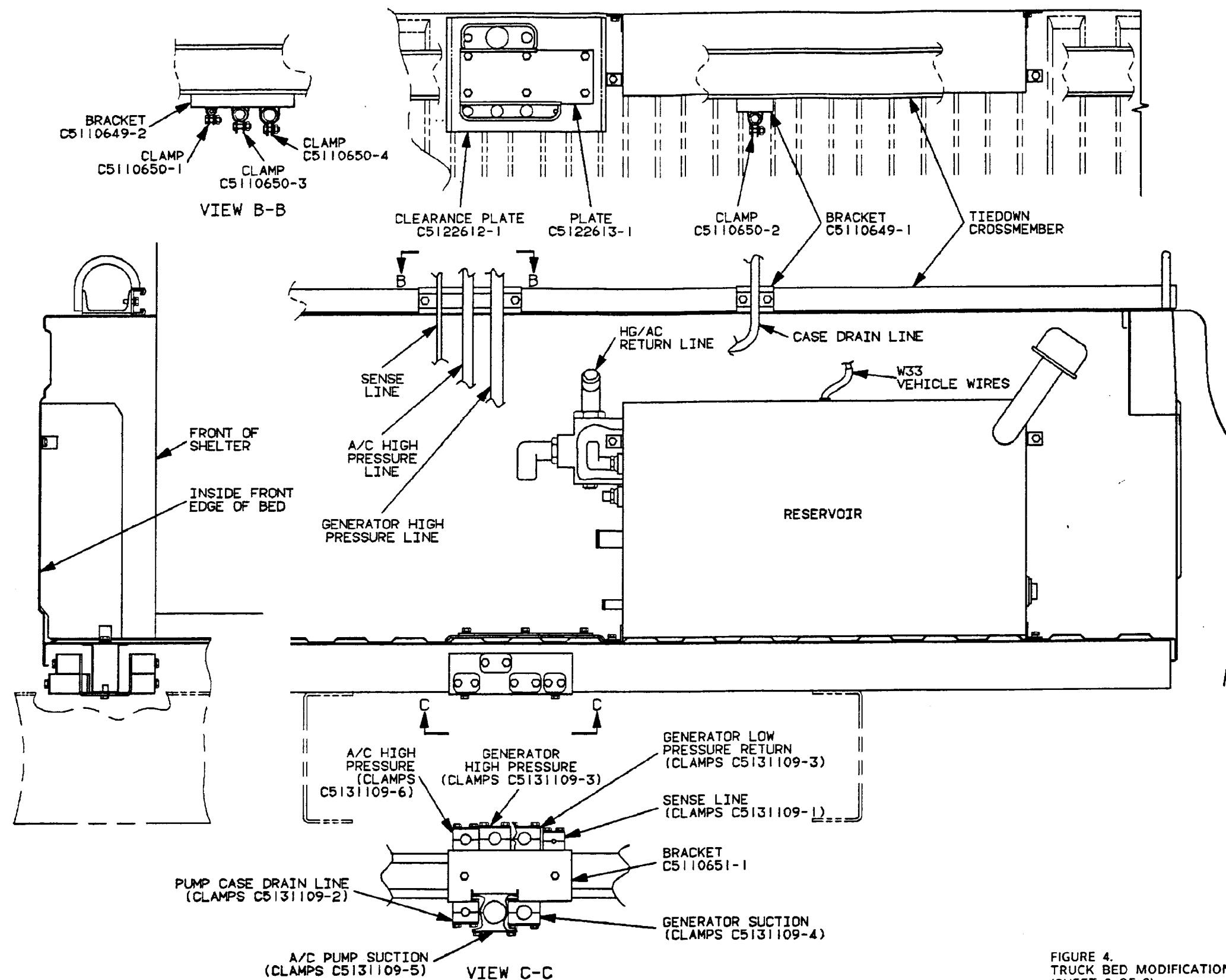

FIGURE 4.
TRUCK BED MODIFICATION DRAWING
(SHEET 2 OF 2)
FP-9/(FP-10 blank)

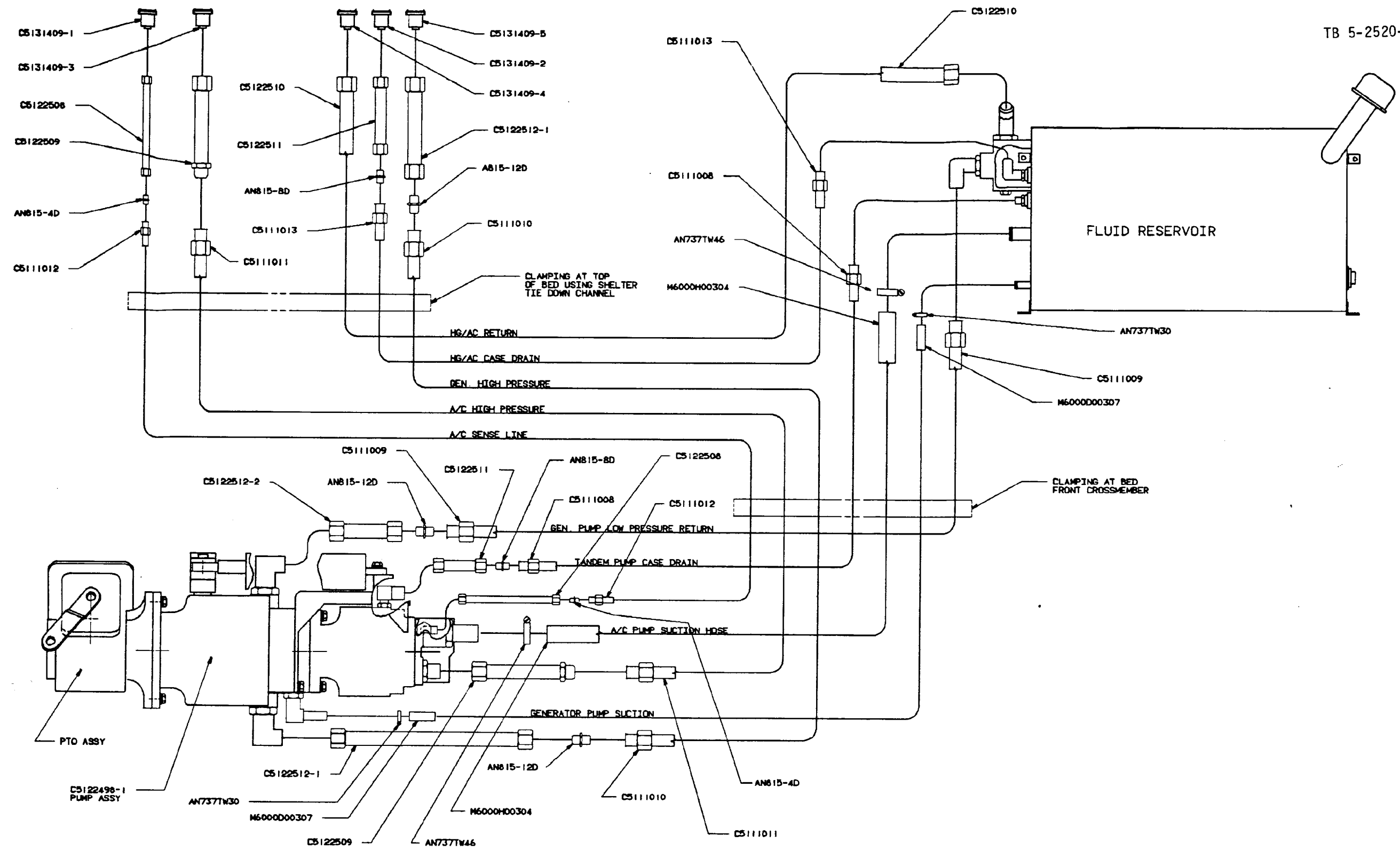

FIGURE 5.
HYDRAULIC LINE LAYOUT
FP-11/(FP-12 blank)

RECOMMENDED CHANGES TO EQUIPMENT TECHNICAL PUBLICATIONS



THEN... JOT DOWN THE DOPE ABOUT IT ON THIS FORM. CAREFULLY TEAR IT OUT. FOLD IT AND DROP IT IN THE MAIL!

SOMETHING WRONG WITH THIS PUBLICATION?

FROM: (PRINT YOUR UNIT'S COMPLETE ADDRESS)

PFC JOHN DOE
COA, 3d ENGINEER BN
FT. LEONARDWOOD, MO 63108

DATE SENT

PUBLICATION NUMBER

TB 5-2520-551-24

PUBLICATION DATE

12 JAN 89

PUBLICATION TITLE

Installations Instructions for
Truck Installation Kit, TRQ-32(V)

BE EXACT... PIN-POINT WHERE IT IS

PAGE NO	PARA-GRAPH	FIGURE NO	TABLE NO
6	2-1 a		
B1		4-3	
125	line 20		

IN THIS SPACE TELL WHAT IS WRONG AND WHAT SHOULD BE DONE ABOUT IT:

In line 6 of paragraph 2-1 a the manual states the engine has 6 cylinders. The engine on my set only has 4 cylinders. Change the manual to show 4 cylinders.

Callout 16 on figure 4-3 is pointing at a bolt. In key to figure 4-3, item 16 is called a shim - Please correct one or the other.

I ordered a gasket, item 19 on figure B-16 by NSN 2 910-00-762-3001. I got a gasket but it doesn't fit. Supply says I got what I ordered, so the NSN is wrong. Please give me a good NSN

PRINTED NAME, GRADE OR TITLE, AND TELEPHONE NUMBER

JOHN DOE, PFC (268) 317-7111

SIGN HERE

JOHN DOE

DA FORM 1 JUL 79 2028-2

PREVIOUS EDITIONS ARE OBSOLETE.

DRSTS-M Overprint 1, 1 Nov 80

PS--IF YOUR OUTFIT WANTS TO KNOW ABOUT YOUR RECOMMENDATION MAKE A CARBON COPY OF THIS AND GIVE IT TO YOUR HEADQUARTERS

TEAR ALONG PERFORATED LINE

FILL IN YOUR
UNIT'S ADDRESS

FOLD BACK

DEPARTMENT OF THE ARMY

OFFICIAL BUSINESS
PENALTY FOR PRIVATE USE \$300

POSTAGE AND FEES PAID
DEPARTMENT OF THE ARMY
DOD 314



TEAR ALONG PERFORATED LINE

COMMANDER
U S ARMY TROOP SUPPORT COMMAND
ATTN: AMSTR-MCTS
4300 GOODFELLOW BOULEVARD
ST. LOUIS, MO 63120-1798

RECOMMENDED CHANGES TO EQUIPMENT TECHNICAL PUBLICATIONS

SOMETHING WRONG WITH THIS PUBLICATION?



THEN... JOT DOWN THE DOPE ABOUT IT ON THIS FORM, CAREFULLY TEAR IT OUT, FOLD IT AND DROP IT IN THE MAIL!

FROM: (PRINT YOUR UNIT'S COMPLETE ADDRESS)

DATE SENT

PUBLICATION NUMBER
TB 5-2520-551-24

PUBLICATION DATE
12 JAN 89

PUBLICATION TITLE
Installation Instructions for
Truck Installation Kit, TRQ-32(V)

BE EXACT... PIN-POINT WHERE IT IS				IN THIS SPACE TELL WHAT IS WRONG AND WHAT SHOULD BE DONE ABOUT IT:
PAGE NO	PARA-GRAPH	FIGURE NO	TABLE NO	

TEAR ALONG PERFORATED LINE

PRINTED NAME, GRADE OR TITLE, AND TELEPHONE NUMBER

SIGN HERE

DA FORM **2028-2**
1 JUL 79

PREVIOUS EDITIONS ARE OBSOLETE.
DRSTS-M Overprint 2, 1 Nov 80.

P.S.--IF YOUR OUTFIT WANTS TO KNOW ABOUT YOUR RECOMMENDATION MAKE A CARBON COPY OF THIS AND GIVE IT TO YOUR HEADQUARTERS.

FILL IN YOUR
UNIT'S ADDRESS

FOLD BACK

DEPARTMENT OF THE ARMY

OFFICIAL BUSINESS
PENALTY FOR PRIVATE USE \$300

POSTAGE AND FEES PAID
DEPARTMENT OF THE ARMY
DOD 314



TEAR ALONG PERFORATED LINE

COMMANDER
U S ARMY TROOP SUPPORT COMMAND
ATTN: AMSTR-MCTS
4300 GOODFELLOW BOULEVARD
ST. LOUIS, MO 63120-1798

RECOMMENDED CHANGES TO EQUIPMENT TECHNICAL PUBLICATIONS



THEN... JOT DOWN THE DOPE ABOUT IT ON THIS FORM. CAREFULLY TEAR IT OUT. FOLD IT AND DROP IT IN THE MAIL!

SOMETHING WRONG WITH THIS PUBLICATION?

FROM: (PRINT YOUR UNIT'S COMPLETE ADDRESS)

DATE SENT

PUBLICATION NUMBER

TM 5-2520-551-24

PUBLICATION DATE

12 JAN 89

PUBLICATION TITLE

Installation Instructions for
Truck Installation Kit, TRQ-32(V)

BE EXACT... PIN-POINT WHERE IT IS

PAGE NO	PARA- GRAPH	FIGURE NO	TABLE NO

IN THIS SPACE TELL WHAT IS WRONG AND WHAT SHOULD BE DONE ABOUT IT:

PRINTED NAME, GRADE OR TITLE, AND TELEPHONE NUMBER

SIGN HERE

TEAR ALONG PERFORATED LINE

DA FORM 2028-2
1 JUL 79

PREVIOUS EDITIONS
ARE OBSOLETE.
DRSTS-M Overprint 2, 1 Nov 80.

PS--IF YOUR OUTFIT WANTS TO KNOW ABOUT YOUR
RECOMMENDATION MAKE A CARBON COPY OF THIS
AND GIVE IT TO YOUR HEADQUARTERS

FILL IN YOUR
UNIT'S ADDRESS

FOLD BACK

DEPARTMENT OF THE ARMY

OFFICIAL BUSINESS
PENALTY FOR PRIVATE USE \$300

POSTAGE AND FEES PAID
DEPARTMENT OF THE ARMY
DOD 314



TEAR ALONG PERFORATED LINE

COMMANDER
U S ARMY TROOP SUPPORT COMMAND
ATTN: AMSTR-MCTS
4300 GOODFELLOW BOULEVARD
ST. LOUIS, MO 63120-1798

RECOMMENDED CHANGES TO EQUIPMENT TECHNICAL PUBLICATIONS



THEN... JOT DOWN THE DOPE ABOUT IT ON THIS FORM. CAREFULLY TEAR IT OUT, FOLD IT AND DROP IT IN THE MAIL!

SOMETHING WRONG WITH THIS PUBLICATION?

FROM: (PRINT YOUR UNIT'S COMPLETE ADDRESS)

DATE SENT

PUBLICATION NUMBER

TB 5-2520-551-24

PUBLICATION DATE

12 JAN 89

PUBLICATION TITLE

Installation Instructions for
Truck Installation Kit, TRQ-32(V)

BE EXACT. PIN-POINT WHERE IT IS

PAGE NO	PARA-GRAPH	FIGURE NO	TABLE NO

IN THIS SPACE TELL WHAT IS WRONG AND WHAT SHOULD BE DONE ABOUT IT:

TEAR ALONG PERFORATED LINE

PRINTED NAME, GRADE OR TITLE, AND TELEPHONE NUMBER

SIGN HERE

DA FORM 2028-2
1 JUL 79

PREVIOUS EDITIONS ARE OBSOLETE.
DRSTS-M Overprint 2, 1 Nov 80.

PS--IF YOUR OUTFIT WANTS TO KNOW ABOUT YOUR RECOMMENDATION MAKE A CARBON COPY OF THIS AND GIVE IT TO YOUR HEADQUARTERS.

FILL IN YOUR
UNIT'S ADDRESS

FOLD BACK

DEPARTMENT OF THE ARMY

OFFICIAL BUSINESS
PENALTY FOR PRIVATE USE \$300

POSTAGE AND FEES PAID
DEPARTMENT OF THE ARMY
DOD 314



TEAR ALONG PERFORATED LINE

COMMANDER
U S ARMY TROOP SUPPORT COMMAND
ATTN: AMSTR-MCTS
4300 GOODFELLOW BOULEVARD
ST. LOUIS, MO 63120-1798

The Metric System and Equivalents

Linear Measure

1 centimeter = 10 millimeters = .39 inch
 1 decimeter = 10 centimeters = 3.94 inches
 1 meter = 10 decimeters = 39.37 inches
 1 dekameter = 10 meters = 32.8 feet
 1 hectometer = 10 dekameters = 328.08 feet
 1 kilometer = 10 hectometers = 3,280.8 feet

Weights

1 centigram = 10 milligrams = .15 grain
 1 decigram = 10 centigrams = 1.54 grains
 1 gram = 10 decigrams = .035 ounce
 1 dekagram = 10 grams = .35 ounce
 1 hectogram = 10 dekagrams = 3.52 ounces
 1 kilogram = 10 hectograms = 2.2 pounds
 1 quintal = 100 kilograms = 220.46 pounds
 1 metric ton = 10 quintals = 1.1 short tons

Liquid Measure

1 centiliter = 10 milliliters = .34 fl. ounce
 1 deciliter = 10 centiliters = 3.38 fl. ounces
 1 liter = 10 deciliters = 33.81 fl. ounces
 1 dekaliter = 10 liters = 2.64 gallons
 1 hectoliter = 10 dekaliters = 26.42 gallons
 1 kiloliter = 10 hectoliters = 264.18 gallons

Square Measure

1 sq. centimeter = 100 sq. millimeters = .155 sq. inch
 1 sq. decimeter = 100 sq. centimeters = 15.5 sq. inches
 1 sq. meter (centare) = 100 sq. decimeters = 10.76 sq. feet
 1 sq. dekameter (are) = 100 sq. meters = 1,076.4 sq. feet
 1 sq. hectometer (hectare) = 100 sq. dekameters = 2.47 acres
 1 sq. kilometer = 100 sq. hectometers = .386 sq. mile

Cubic Measure

1 cu. centimeter = 1000 cu. millimeters = .06 cu. inch
 1 cu. decimeter = 1000 cu. centimeters = 61.02 cu. inches
 1 cu. meter = 1000 cu. decimeters = 35.31 cu. feet

Approximate Conversion Factors

To change	To	Multiply by	To change	To	Multiply by
inches	centimeters	2.540	ounce-inches	newton-meters	.007062
feet	meters	.305	centimeters	inches	.394
yards	meters	.914	meters	feet	3.280
miles	kilometers	1.609	meters	yards	1.094
square inches	square centimeters	6.451	kilometers	miles	.621
square feet	square meters	.093	square centimeters	square inches	.155
square yards	square meters	.836	square meters	square feet	10.764
square miles	square kilometers	2.590	square meters	square yards	1.196
acres	square hectometers	.405	square kilometers	square miles	.386
cubic feet	cubic meters	.028	square hectometers	acres	2.471
cubic yards	cubic meters	.765	cubic meters	cubic feet	35.315
fluid ounces	milliliters	29.573	cubic meters	cubic yards	1.308
pints	liters	.473	milliliters	fluid ounces	.034
quarts	liters	.946	liters	pints	2.113
gallons	liters	3.785	liters	quarts	1.057
ounces	grams	28.349	liters	gallons	.264
pounds	kilograms	.454	grams	ounces	.035
short tons	metric tons	.907	kilograms	pounds	2.205
pound-feet	newton-meters	1.356	metric tons	short tons	1.102
pound-inches	newton-meters	.11296			

Temperature (Exact)

°F	Fahrenheit temperature	5/9 (after subtracting 32)	Celsius temperature	°C
----	------------------------	----------------------------	---------------------	----

PIN: 065278 000